

| | | |
|--|--|--|
| <p>PKG. OF 2</p>  <p>18-2945 AP# 2108 DRAIN/FILL WASHER GASKET</p> |  <p>18-2563 AP# 1484 COVER TO WEAR PLATE GASKET Replaces: 19232-ZW1-003</p> |  <p>18-2564 AP# 1483 WEAR PLATE TO BASE GASKET Replaces: 19234-ZW1-003</p> |
|  <p>18-2565 AP# 1485 PUMP BASE TO HOUSING GASKET Replaces: 19242-ZW1-003</p> |  <p>18-7720 COMPLETE FUEL FILTER Replaces: 16900-SR3-004 For: BF115,BF130,AX,AY,A1 Series#14ZW50E1M</p> |  <p>18-7786 COMPLETE FUEL FILTER Replaces: 16900-SR5-004 For: BF35/45AM,BF4050A,AW,AX Series#14ZV50M:BF75,BF90,AT,AW,AX,AY Series#14ZW00E1M</p> |
|  <p>18-7785 COMPLETE FUEL FILTER Replaces: 16010-ST5-993 For: BF115,BF130,AX,AY,A1 Series#14ZW50E1M</p> |  <p>18-3056 IMPELLER Replaces: 19210-ZW1-003 For: 75-90 HP</p> |  <p>18-3245 IMPELLER Replaces: 19210-881-A01 For: 5, 7.5, 8, 10 HP</p> |
|  <p>18-3246 IMPELLER Replaces: 19210-ZV4-013 For: BF9.9,BF15,AH,AK,AM,AW Series#14ZV40M</p> |  <p>18-3247 IMPELLER Replaces: 19210-ZV4-651 For: 8, 9.9, 15 HP</p> |  <p>18-3248 IMPELLER Replaces: 19210-ZV5-003 For: 35, 40, 45, 50 HP</p> |

| | | |
|---|--|---|
|  <p>18-3249 IMPELLER Replaces: 19210-ZV7-003 For: 20, 25, 30 HP</p> |  <p>18-3250 IMPELLER Replaces: 19210-ZW1-B04 For: 75, 90, 115, 130 HP</p> |  <p>18-3122 AP# 2187 WEAR PLATE Replaces: 19231-ZW1-003 For: 75-90 HP</p> |
|  <p>18-3214 AP# 1811 WATER PUMP KIT Replaces: 19210-ZWL-303 For: 75-90 HP</p> |  <p>18-1156 AP# 1906 FORWARD GEAR BEARING Replaces: 91051-ZW1-003</p> |  <p>18-1158 AP# 2126 CARRIER BEARING Replaces: 91053-ZW1-003</p> |
|  <p>18-1157 AP# 2125 FORWARD GEAR INNER BEARING Replaces: 91057-ZW1-003</p> |  <p>18-6011 AP# 4000 TRIM TAB Replaces: 41107-ZW1-0032A Standard – 2 1/4" long</p> |  <p>18-6068 ANODE Replaces: 41109-ZW1-003</p> |
|  <p>18-6025 ANODE Replaces: 41107-ZV5-00</p> |  <p>18-7910 AP# 6015 OIL FILTER Replaces: 15400-POH-30, 15400-POH-305PI For: 75 HP & UP BF75,BF90,AT,AW,AX,AY Series # 14ZW00E1M,BF115,BF130,AX,AY,A1 Series# 14ZW50E1M</p> |  <p>18-7911 OIL FILTER Replaces: 15400-PFB-004 For: BF25,BF30,A,AW,AX,AY, Series# 14ZV90E1M, BF34/45AM, BF40/50A,AW,AX, Series# 14ZV50M</p> |

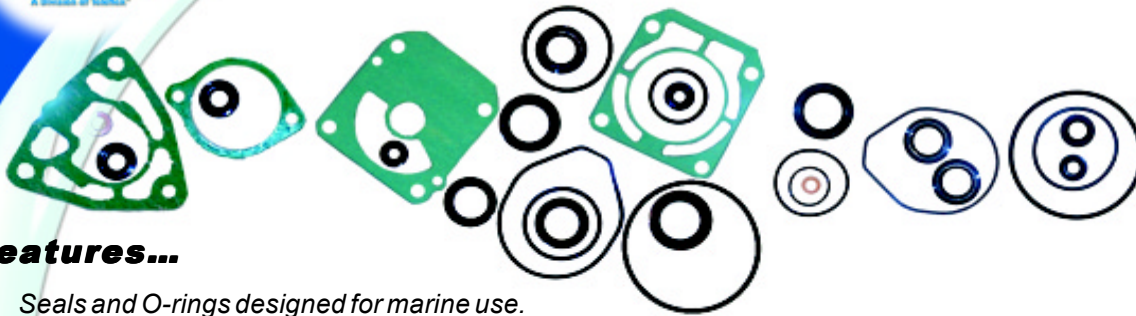

Lower Unit Seal Kits



Features...

- ★ Seals and O-rings designed for marine use.
- ★ Kits include all necessary parts to do a complete reseal.
- ★ Easy, quick reference application charts.
- ★ Sierra exclusive seal kits are not available from Honda.

| <p>18-8362 LOWER UNIT SEAL KIT</p> | <p>18-8363 LOWER UNIT SEAL KIT</p> | <p>18-8364 LOWER UNIT SEAL KIT</p> | | | | | | | | | | | | | | | | | | | | | | | | |
|--|---|--|---------------|----------|---------------|-------------|---------|---------|----------------------------|---------------|--------------|---------|---------------|---------------|---------|-----|------------|---------------|---------|-----|------------|---------------|---------|-----|-------------|---------------|
| <p>18-8365 LOWER UNIT SEAL KIT</p> | <p>18-8366 LOWER UNIT SEAL KIT</p> | <p>LOWER UNIT SEAL KIT APPLICATION</p> <table border="1"> <thead> <tr> <th>HP/Model</th> <th>Sierra #</th> </tr> </thead> <tbody> <tr> <td>BF 9.9, BF 15</td> <td>18-8363</td> </tr> <tr> <td>BF 20</td> <td>18-8364</td> </tr> <tr> <td>BF 35, BF 40, BF 45, BF 50</td> <td>18-8362</td> </tr> <tr> <td>BF 75, BF 90</td> <td>18-8366</td> </tr> <tr> <td>BF115, BF130</td> <td>18-8365</td> </tr> </tbody> </table> | HP/Model | Sierra # | BF 9.9, BF 15 | 18-8363 | BF 20 | 18-8364 | BF 35, BF 40, BF 45, BF 50 | 18-8362 | BF 75, BF 90 | 18-8366 | BF115, BF130 | 18-8365 | | | | | | | | | | | | |
| HP/Model | Sierra # | | | | | | | | | | | | | | | | | | | | | | | | | |
| BF 9.9, BF 15 | 18-8363 | | | | | | | | | | | | | | | | | | | | | | | | | |
| BF 20 | 18-8364 | | | | | | | | | | | | | | | | | | | | | | | | | |
| BF 35, BF 40, BF 45, BF 50 | 18-8362 | | | | | | | | | | | | | | | | | | | | | | | | | |
| BF 75, BF 90 | 18-8366 | | | | | | | | | | | | | | | | | | | | | | | | | |
| BF115, BF130 | 18-8365 | | | | | | | | | | | | | | | | | | | | | | | | | |
| <p>18-6504 REWIND SPRING</p> <p>Replaces: 28451-921-000 For: BF 75 (7.5 HP) FF100 (9.9 HP)</p> | <p>PKG. OF 10</p> <p>18-3200 TAB WASHER</p> <p>Replaces: 90508-ZW1-003 For: 75-90 HP</p> | <p>18-3701 AP# 122 PROP NUT & TAB WASHER KIT</p> <p>— CONTAINS —</p> <table border="1"> <thead> <tr> <th>Sierra #</th> <th>AP#</th> <th>O.E. #</th> <th>Description</th> </tr> </thead> <tbody> <tr> <td>18-3200</td> <td>2708</td> <td>90508-ZW1-003</td> <td>Tab Washer</td> </tr> <tr> <td>18-3700</td> <td>—</td> <td>90301-ZW1-003</td> <td>Prop Nut</td> </tr> </tbody> </table> | Sierra # | AP# | O.E. # | Description | 18-3200 | 2708 | 90508-ZW1-003 | Tab Washer | 18-3700 | — | 90301-ZW1-003 | Prop Nut | | | | | | | | | | | | |
| Sierra # | AP# | O.E. # | Description | | | | | | | | | | | | | | | | | | | | | | | |
| 18-3200 | 2708 | 90508-ZW1-003 | Tab Washer | | | | | | | | | | | | | | | | | | | | | | | |
| 18-3700 | — | 90301-ZW1-003 | Prop Nut | | | | | | | | | | | | | | | | | | | | | | | |
| <p>18-7198 AP# 220 O-RING</p> <p>Replaces: 91353-ZW1-003</p> | <p>OIL SEALS</p> <table border="1"> <thead> <tr> <th>Sierra#</th> <th>AP #</th> <th>Description</th> <th>O.E. #</th> </tr> </thead> <tbody> <tr> <td>18-0522</td> <td>1442</td> <td>Drive Shaft</td> <td>91254-ZW1-003</td> </tr> <tr> <td>18-0583</td> <td>1441</td> <td>Drive Shaft</td> <td>91251-ZW1-003</td> </tr> <tr> <td>18-2002</td> <td>238</td> <td>Prop Shaft</td> <td>91252-ZW1-003</td> </tr> <tr> <td>18-2053</td> <td>145</td> <td>Prop Shaft</td> <td>91255-ZW1-003</td> </tr> <tr> <td>18-2054</td> <td>196</td> <td>Shift Shaft</td> <td>91253-ZW1-003</td> </tr> </tbody> </table> | | Sierra# | AP # | Description | O.E. # | 18-0522 | 1442 | Drive Shaft | 91254-ZW1-003 | 18-0583 | 1441 | Drive Shaft | 91251-ZW1-003 | 18-2002 | 238 | Prop Shaft | 91252-ZW1-003 | 18-2053 | 145 | Prop Shaft | 91255-ZW1-003 | 18-2054 | 196 | Shift Shaft | 91253-ZW1-003 |
| Sierra# | AP # | Description | O.E. # | | | | | | | | | | | | | | | | | | | | | | | |
| 18-0522 | 1442 | Drive Shaft | 91254-ZW1-003 | | | | | | | | | | | | | | | | | | | | | | | |
| 18-0583 | 1441 | Drive Shaft | 91251-ZW1-003 | | | | | | | | | | | | | | | | | | | | | | | |
| 18-2002 | 238 | Prop Shaft | 91252-ZW1-003 | | | | | | | | | | | | | | | | | | | | | | | |
| 18-2053 | 145 | Prop Shaft | 91255-ZW1-003 | | | | | | | | | | | | | | | | | | | | | | | |
| 18-2054 | 196 | Shift Shaft | 91253-ZW1-003 | | | | | | | | | | | | | | | | | | | | | | | |



18-5009
AP# 13343
TUNE-UP KIT
 — CONTAINS —

| Sierra # | AP # | O.E.# | Description |
|----------|-------|----------|-------------|
| 18-5161 | 732 | 38850127 | Contact Set |
| 18-5241 | 13385 | 38850115 | Condenser |

For 10 H.P. 1958



18-5153
AP# 13360
CONTACT SET
 Replaces: 75101A,
 1340135, 36550135



18-5161
AP# 13362
CONTACT SET
 Replaces: 38850127



18-5162
AP# 13363
CONTACT SET
 Replaces: 73739



18-5236
CONDENSER
 Replaces: 76067, 36850115



18-5241
AP# 13385
CONDENSER
 Replaces: 38850115

| HP | Years | Sierra Contact Set | AP Contact Set | Sierra Condenser | AP Condenser |
|----------|---------|--------------------|----------------|------------------|--------------|
| 3.6 | 1953-57 | 18-5153 | 13360 | — | — |
| 3.6 | 1958-59 | 18-5161 ① | 13362 ① | — | — |
| 5 | 1958-59 | 18-5161 ① ② ④ | 13362 ① ② ④ | — | — |
| 6 | 1960-62 | 18-5153 ② | 13360 ② | — | — |
| 7.5 | 1952-87 | 18-5153 ② | 13360 ② | — | — |
| 7.5 | 1958 | 18-5153 ② ③ | 13360 ② ③ | — | — |
| 7.5 | 1958 | 18-5161 ① ② | 13362 ① ② | — | — |
| 7.5 | 1960 | 18-5153 ② | 13360 ② | — | — |
| 7.5 | 1961-68 | 18-5153 ② | 13360 ② | — | — |
| 10 | 1958 | 18-5161 ② | 13362 ② | 18-5241 ② | 13385 ② |
| 22 | 1958 | 18-5162 ② | 13363 ② | 18-5236 ② | — |
| 25 | 1959 | 18-5153 ② ③ | 13360 ② ③ | — | — |
| 25 | 1959-60 | 18-5162 ① ② | 13363 ① ② | 18-5236 ① ② | — |
| 28 | 1961-68 | 18-5162 ② | 13363 ② | 18-5236 ② | — |
| 30 to 33 | 1955-56 | 18-5153 ② | 13360 ② | — | — |
| 40 | 1957-59 | 18-5153 ② ③ | 13360 ② ③ | — | — |
| 40 | 1958-60 | 18-5162 ① ② | 13363 ① ② | 18-5236 ① ② | — |
| 43.7 | 1961-62 | 18-5162 ② | 13363 ② | 18-5236 ② | — |
| 45 | 1963-67 | 18-5162 ② | 13363 ② | 18-5236 ② | — |
| 50 | 1964 | 18-5162 ② | 13363 ② | 18-5236 ② | — |

① WICO Magneto Only ② Two Required ③ REPCO Magneto Only ④ Models without "M" S/N Only

OUTBOARD



Display Package

18-5101
AP# 13347
MAGNATUNE™ IGNITION KIT
For 2 Cylinder Outboards

—CONTAINS—

Two 18-5100 Magnatune™ Ignition Modules Solid State Electronic Replacement for Mechanical Contact Sets and Condensers in McCulloch Outboards with Dual Point Magneto Systems. Includes Installation Instructions and All Necessary Hardware. Not For Engines With Charging Systems



18-5225
AP# 13382
SPARK PLUG WIRE KIT

Kit includes 25 ft Roll of Hypalon Ignition Wire With a Copper Conductor and a Large Assortment of Three Different End Fittings to Fit McCulloch Motors Wire available in 100' Spool 18-5226/AP# 13383

OUTBOARD

SILVERADO 2000
SAE J 1527 USCG
Type B2
Premium Fuel Line

| Sierra # | AP # | I.D. | Length |
|----------|-------|-------|--------|
| 18-8013 | 13534 | 5/16" | 8' |
| 18-8015 | 2571 | 3/8" | 8' |
| 18-8032 | 3805 | 5/16" | 12' |

SILVERADO 1000
Economy Fuel Line

| Sierra # | AP # | I.D. | Length |
|----------|------|-------|--------|
| 18-8065 | — | 5/16" | 8' |
| 18-8033 | — | 5/16" | 12' |

ALCOHOL RESISTANT



Display Package

UNIVERSAL FUEL LINE ASSEMBLY



Display Package

PRIMER BULB ASSEMBLY

Comes complete with two Hose Clamps

| Sierra # | AP # | Description |
|----------|-------|--------------------------------------|
| 18-8002 | 13530 | For 1/4" I.D. Hose |
| 18-8004 | — | For 5/16" I.D. (large capacity bulb) |
| 18-8005 | 3881 | For 3/8" I.D. (large capacity bulb) |



Display Package

18-7852-1
AP# 6030
FUEL WATER SEPARATOR FILTER WITH BRACKET

Includes:
18-7845/AP# 6041 Filter - 18-7853-1/AP# 6050 Bracket
18-4256 1/4" (2) Brass Plugs
18-9004/AP# 3914 Pipe Sealant with Teflon® is recommended for use on filter bracket fitting threads



Display Package

18-7828
AP# 13518
(1/4" Small)

18-7829
AP# 600
(1/4" Large)

18-7830
AP# 1227
(5/16")

18-7831
AP# 1679
(3/8")

INLINE FUEL FILTER



18-3009
IMPELLER
Replaces: 73055



18-3010
IMPELLER
Replaces: 37855100

| HP | YEAR | PART # | HP | YEAR | PART # |
|-----|---------|---------|----|---------|---------|
| 5 | 1954-58 | 18-3009 | 9 | 1967-68 | 18-3009 |
| 7.5 | 1960-69 | 18-3009 | 10 | 1954-58 | 18-3010 |

Fuel Line Assemblies













| 2000 Silverado | | 1000 Silverado | | Millennium | |
|---------------------------------|-------|----------------|------|------------|---|
| Sierra # | AP # | Sierra # | AP # | I.D. | End Connectors |
| Nissan/Tohatsu 8' Length | | | | | |
| 18-8027 | 13538 | 18-8028 | — | 5/16 | Engine 18-8088 or 13543 Tank 18-8079 |
| Universal 8' Length | | | | | |
| 18-8013 | 13534 | 18-8065 | — | 5/16 | No end fittings |
| 18-8015 | 2571 | 18-8080 | 2571 | 3/8 | No end fittings |
| 12' Length | | | | | |
| 18-8032 | 3805 | 18-8033 | 3805 | 5/16 | No end fittings |





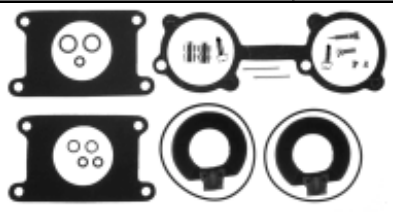

FUEL LINE ASSEMBLY

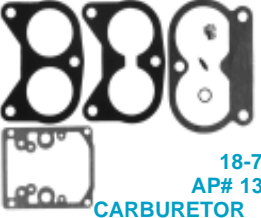

UNIVERSAL FUEL LINE ASSEMBLY

|  <p>18-8088 AP# 13543 FUEL LINE CONNECTOR Replaces: 345-70250-0 Engine End • 3/8" Hose</p> |  <p>18-8089 AP# 13544 ENGINE CONNECTOR Replaces: 3B2-70260-0 Metric Threads • 5/16" hose</p> |  <p>18-8078 AP# 883 FUEL TANK CONNECTOR 1/4" N.P.T. .508 O.D. Large Inlet</p> |  <p>18-8079 AP # 2212 FUEL LINE CONNECTOR Replaces: 3B2-70281-0 Tank End</p> | | | | | | | | | |
|---|--|--|---|---------|---|------|---------|------|-----|---|--|---|
|  <p>PRIMER BULB ASSEMBLY</p> <table border="1" style="width: 100%; border-collapse: collapse;"> <thead> <tr> <th>SIERRA #</th> <th>AP #</th> <th>FITS HOSE I.D.</th> </tr> </thead> <tbody> <tr> <td>18-8004</td> <td>—</td> <td>5/16</td> </tr> <tr> <td>18-8005</td> <td>3881</td> <td>3/8</td> </tr> </tbody> </table> <p>Alcohol Resistant</p> | SIERRA # | AP # | FITS HOSE I.D. | 18-8004 | — | 5/16 | 18-8005 | 3881 | 3/8 |  <p>INLINE FUEL FILTER</p> <p>18-7828/AP# 13518 (1/4" Small) Small Capacity (For 1/4" Fuel Line)</p> <p>18-7829/AP# 600 (1/4" Large) Large Capacity (For 1/4" Fuel Line)</p> <p>18-7830/AP# 1227 (5/16") 18-7831/AP# 1679 (3/8")</p> |  <p>SNAPPER CLAMPS</p> <p>18-8020 #8 For 5/16" Hose AP# 1371</p> <p>18-8021 #10 For 3/8" Hose AP# 1372</p> | <p>NEW</p>  <p>18-6786 TRIM/MOTOR V-6, 2 -wire hook-up 3 bolt flange</p> |
| SIERRA # | AP # | FITS HOSE I.D. | | | | | | | | | | |
| 18-8004 | — | 5/16 | | | | | | | | | | |
| 18-8005 | 3881 | 3/8 | | | | | | | | | | |
|  <p>18-7290 AP# 13482 CARBURETOR KIT Replaces: 345-87122-0 Kit contains enough components to rebuild 2 carburetors FOR: ALL 35/40C HP (1 per engine)</p> |  <p>18-7291 AP# 13483 CARBURETOR KIT Replaces: 346-87122-0 FOR: ALL 25/30 HP (1 per engine); ALL 45A2, 50C, 60C, 70A2 (2 per engine)</p> |  <p>18-7765 AP# 13501 CARBURETOR KIT Replaces: 369-87122-1 FOR: ALL 4/5 HP (1 per engine)</p> | | | | | | | | | | |
|  <p>18-7845 AP# 6031 FUEL FILTER</p> | <p>18-7852-1 AP# 6030 FUEL WATER SEPARATOR FILTER WITH BRACKET</p> <p>Includes: 18-7845/AP# 6031 Filter 18-7853-1/AP# 6050 Bracket 18-4256 1/4" (2) Brass Plug 18-9004/AP# 3914 Pipe Sealant with Teflon is recommended for use on filter bracket fitting threads</p> | |  | | | | | | | | | |

| | | |
|--|--|---|
|  <p>18-9802 TIMING LIGHT Self-powered accurate up to 10,000 RPM's</p> | <p>NEW</p>  <p>18-6785 TRIM/MOTOR V-6/3 wire hook-up 3 bolt flange</p> | <p>NEW</p>  <p>18-6786 TRIM/MOTOR Replaces: 38100-87D10-0ED, 38100-87D10-35J, 38100-87D10-0IT 3 Bolt flange 2 wire connection</p> |
|--|--|---|

| | | | |
|--|--|---|--|
|  <p>18-7752 AP# 13497 CARBURETOR KIT Replaces: 13910-87D00</p> |  <p>18-7753 AP# 13498 CARBURETOR KIT Replaces: 13910-94400</p> |  <p>18-7754 AP# 13499 CARBURETOR KIT Replaces: 13910-94701</p> |  <p>18-7755 AP# 13500 CARBURETOR KIT Replaces: 13910-95D00</p> |
|--|--|---|--|





| HP/Model | Year | Sierra # | AP# | HP/Model | Year | Sierra # | AP# | HP/Model | Year | Sierra # | AP# |
|----------|---------|----------|-------|----------|---------|----------|-------|----------|---------|----------|-------|
| DT25C | 1989-98 | 18-7755 | 13500 | DT65 | 1985-97 | 18-7753 | 13498 | DT100 | 1989-98 | 18-7752 | 13497 |
| DT30C | 1988-97 | 18-7755 | 13500 | DT75 | 1985-97 | 18-7754 | 13499 | DT115 | 1986-98 | 18-7754 | 13499 |
| DT40C | 1984-98 | 18-7753 | 13498 | DT85 | 1985-98 | 18-7753 | 13498 | DT140 | 1986-98 | 18-7753 | 13498 |
| DT55 | 1985-97 | 18-7754 | 13499 | DT90 | 1989-97 | 18-7752 | 13497 | V-6 | ALL | 18-7752 | 13497 |





OUTBOARD

Fuel Line Assemblies

| 2000 Silverado | | 1000 Silverado | | Millennium | | | |
|----------------------------|-------|----------------|------|------------|-------------|--------------------|--|
| Sierra # | AP # | Sierra # | AP # | I.D. | O.E. # | End Connectors | |
| Suzuki 8' Length | | | | | | | |
| 18-8018 | — | — | 2577 | 5/16 | 65700-95513 | (2) 18-8079 or 884 | |
| 18-8019 | 13535 | — | — | 5/16 | — | (2) 18-8062 or 822 | |
| Universal 8' Length | | | | | | | |
| 18-8013 | 13534 | 18-8065 | — | 5/16 | — | No end fittings | |
| 18-8015 | 2571 | 18-8080 | 2571 | 3/8 | 174513 | No end fittings | |
| 12' Length | | | | | | | |
| 18-8032 | 3805 | 18-8033 | 3805 | 5/16 | — | No end fittings | |



|  <p>18-8106 AP# 2211 FUEL CONNECTOR For: Chrysler, Eska, Force & Suzuki below 60 HP Corrosion resistant chrome plated brass</p> |  <p>18-8079 AP# 2212 FUEL CONNECTOR Replaces: 65750-95500 For: Suzuki 60 HP & UP Also for Nissan & Tohatsu Corrosion resistant chrome plated brass</p> |  <p>FUEL TANK CONNECTOR</p> <table border="1"> <thead> <tr> <th>Sierra #</th> <th>AP #</th> <th>Inlet</th> <th>Replaces:</th> </tr> </thead> <tbody> <tr> <td>18-8071</td> <td>821</td> <td>Small</td> <td>99105-00192</td> </tr> <tr> <td>18-8078</td> <td>883</td> <td>Large</td> <td>65740-95500, 99105-00193</td> </tr> </tbody> </table> | Sierra # | AP # | Inlet | Replaces: | 18-8071 | 821 | Small | 99105-00192 | 18-8078 | 883 | Large | 65740-95500, 99105-00193 |  <p>FUEL LINE CONNECTOR</p> <table border="1"> <thead> <tr> <th>Sierra #</th> <th>AP #</th> <th>Inlet</th> <th>Replaces:</th> </tr> </thead> <tbody> <tr> <td>18-8062</td> <td>822</td> <td>Small</td> <td>65750-98505</td> </tr> <tr> <td>18-8079</td> <td>—</td> <td>Large</td> <td>65750-95510</td> </tr> </tbody> </table> | Sierra # | AP # | Inlet | Replaces: | 18-8062 | 822 | Small | 65750-98505 | 18-8079 | — | Large | 65750-95510 |
|---|--|--|-----------------------------|------|-------|-----------|---------|-----|-------|-------------|---------|-----|-------|-----------------------------|--|----------|------|-------|-----------|---------|-----|-------|-------------|---------|---|-------|-------------|
| Sierra # | AP # | Inlet | Replaces: | | | | | | | | | | | | | | | | | | | | | | | | |
| 18-8071 | 821 | Small | 99105-00192 | | | | | | | | | | | | | | | | | | | | | | | | |
| 18-8078 | 883 | Large | 65740-95500, 99105-00193 | | | | | | | | | | | | | | | | | | | | | | | | |
| Sierra # | AP # | Inlet | Replaces: | | | | | | | | | | | | | | | | | | | | | | | | |
| 18-8062 | 822 | Small | 65750-98505 | | | | | | | | | | | | | | | | | | | | | | | | |
| 18-8079 | — | Large | 65750-95510 | | | | | | | | | | | | | | | | | | | | | | | | |

|  <p>18-8087 FUEL TANK CONNECTOR (Metric Thread) Replaces: 65720-94411</p> |  <p>18-8090 FUEL TANK CONNECTOR (1/4" NPT)</p> |  <p>PRIMER BULB ASSEMBLY Comes complete with two hose clamps</p> <table border="1"> <thead> <tr> <th>Sierra #</th> <th>AP #</th> <th>Description</th> </tr> </thead> <tbody> <tr> <td>18-8002</td> <td>13530</td> <td>For 1/4" I.D. Hose</td> </tr> <tr> <td>18-8004</td> <td>—</td> <td>For 5/16" I.D. Hose</td> </tr> <tr> <td>18-8005</td> <td>3881</td> <td>For 3/8" I.D. Hose</td> </tr> </tbody> </table> <p>⊕ Large Capacity Bulb</p> | Sierra # | AP # | Description | 18-8002 | 13530 | For 1/4" I.D. Hose | 18-8004 | — | For 5/16" I.D. Hose | 18-8005 | 3881 | For 3/8" I.D. Hose |  <p>INLINE FUEL FILTERS</p> <table border="1"> <thead> <tr> <th>Sierra #</th> <th>AP#</th> <th>Application:</th> </tr> </thead> <tbody> <tr> <td>18-7828</td> <td>13518</td> <td>1/4" Small Capacity (For 1/4" Fuel Line)</td> </tr> <tr> <td>18-7829</td> <td>600</td> <td>1/4" Large Capacity (For 1/4" Fuel Line)</td> </tr> <tr> <td>18-7830</td> <td>1227</td> <td>5/16"</td> </tr> <tr> <td>18-7831</td> <td>1679</td> <td>3/8"</td> </tr> </tbody> </table> | Sierra # | AP# | Application: | 18-7828 | 13518 | 1/4" Small Capacity (For 1/4" Fuel Line) | 18-7829 | 600 | 1/4" Large Capacity (For 1/4" Fuel Line) | 18-7830 | 1227 | 5/16" | 18-7831 | 1679 | 3/8" |
|--|---|--|----------|------|-------------|---------|-------|--------------------|---------|---|---------------------|---------|------|--------------------|---|----------|-----|--------------|---------|-------|--|---------|-----|--|---------|------|-------|---------|------|------|
| Sierra # | AP # | Description | | | | | | | | | | | | | | | | | | | | | | | | | | | | |
| 18-8002 | 13530 | For 1/4" I.D. Hose | | | | | | | | | | | | | | | | | | | | | | | | | | | | |
| 18-8004 | — | For 5/16" I.D. Hose | | | | | | | | | | | | | | | | | | | | | | | | | | | | |
| 18-8005 | 3881 | For 3/8" I.D. Hose | | | | | | | | | | | | | | | | | | | | | | | | | | | | |
| Sierra # | AP# | Application: | | | | | | | | | | | | | | | | | | | | | | | | | | | | |
| 18-7828 | 13518 | 1/4" Small Capacity (For 1/4" Fuel Line) | | | | | | | | | | | | | | | | | | | | | | | | | | | | |
| 18-7829 | 600 | 1/4" Large Capacity (For 1/4" Fuel Line) | | | | | | | | | | | | | | | | | | | | | | | | | | | | |
| 18-7830 | 1227 | 5/16" | | | | | | | | | | | | | | | | | | | | | | | | | | | | |
| 18-7831 | 1679 | 3/8" | | | | | | | | | | | | | | | | | | | | | | | | | | | | |

Bracket Features...

- NEW** **STAINLESS STEEL** Bracket made of marine grade 316 for ultimate corrosion protection and durability. Available in 1/4" and 3/8" inlet/outlet versions.
- NEW** **ALUMINUM** Bracket 3/8" inlet/outlet for easy installation on high-horsepower boats.

Filter Features...

- ★ 28 Micron filter element shaped into 66 pleats. More pleats means more capacity.
- ★ Steel end caps on elements.
- ★ Heavy duty spring.
- ★ Powder coated outside, epoxy coated inside for corrosion protection.
- ★ Meets OEM specifications.
- ★ Will not separate 2 cycle oil from gasoline.
- ★ Do not use with diesel fuel.
- ★ Made in the U.S.A.
- ★ Best flow rate of all major brands
- ★ New attractive retail packaging

18-7852-1
AP# 6030
FUEL WATER SEPARATOR
FILTER WITH BRACKET

Replaces: 99105-20001
 Includes:
 18-7845/AP# 6031 Filter - 18-7853-1/AP# 6050 Bracket
 18-4256 1/4" (2) Brass Plug



Display Package



18-3092
AP# 13151
IMPELLER
 Replaces: 17461-93001



18-3093
AP# 13152
IMPELLER
 Replaces: 17461-93901



18-3094
AP# 2176
IMPELLER
 Replaces: 17461-94700



18-3095
AP# 2177
IMPELLER
 Replaces: 17461-95300



18-3096
AP# 13153
IMPELLER
 Replaces: 17461-96301,
 17461-96311



18-3097
AP# 13154
IMPELLER
 Replaces: 17461-98501

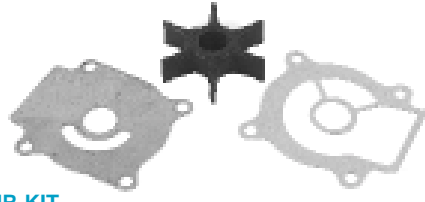

18-3242
AP# 2878
IMPELLER REPAIR KIT
 Replaces: 17400-96350,
 17400-96351

| — CONTAINS — | | Key | | N/A | |
|--------------|---------|----------|-------------|-------|---------|
| MODEL | YEAR | MODEL | YEAR | MODEL | YEAR |
| DT20 | 1986-88 | DT30C | 1988-95 | | |
| DT25 | 1984-88 | DT35 | 1987-89 | | |
| 18-3096 | 13153 | Impeller | 17461-96311 | DT30 | 1984-87 |
| 18-0461 | 2868 | Gasket | 17472-96301 | DT25C | 1989-95 |

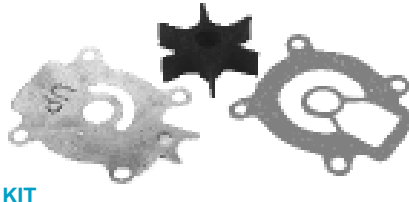

18-3243
AP# 2879
IMPELLER REPAIR KIT
 Replaces: 17400-94700

| — CONTAINS — | | Key | | N/A | |
|--------------|------|----------|-------------|-------|---------|
| MODEL | YEAR | MODEL | YEAR | MODEL | YEAR |
| 18-3094 | 2176 | Impeller | 17461-94700 | | |
| 18-0460 | 2876 | Gasket | 17472-95310 | DT55 | 1985-95 |
| | | | | DT65 | 1985-95 |



18-3244
AP# 2880
IMPELLER REPAIR KIT
 Replaces: 17400-95550

| — CONTAINS — | | Key | | N/A | |
|--------------|------|----------|-------------|-------|---------|
| MODEL | YEAR | MODEL | YEAR | MODEL | YEAR |
| 18-3095 | 2177 | Impeller | 17461-95300 | | |
| 18-0459 | 2877 | Gasket | 17472-95200 | DT75 | 1985-95 |
| | | | | DT85 | 1985-95 |

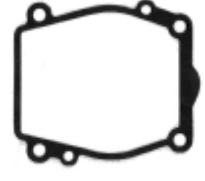

18-0456
AP# 13003
WATER PUMP GASKET
 Replaces: 17472-87D10



18-0457
AP# 13004
WATER PUMP GASKET
 Replaces: 17472-87E10





18-0458
AP# 13005
WATER PUMP GASKET
 Replaces: 17472-94510







18-0459
AP# 13005
WATER PUMP GASKET
 Replaces: 17472-95200

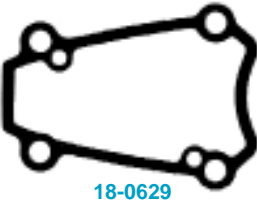
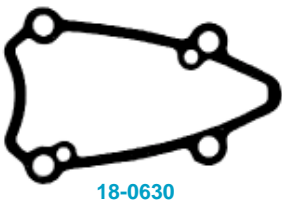

IMPELLER APPLICATION ON NEXT PAGE



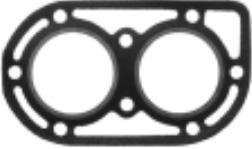
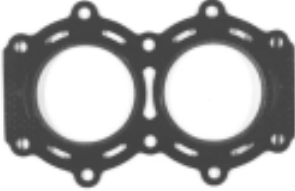

OUTBOARD

| | | | |
|---|---|--|---|
|  <p>18-0460 AP# 2876 WATER PUMP GASKET Replaces: 17472-95310</p> |  <p>18-0461 AP# 2868 WATER PUMP GASKET Replaces: 17472-96301</p> |  <p>18-0629 AP# 13009 SHIFT GUIDE HOUSING GASKET Replaces: 25142-94520</p> |  <p>18-0630 AP# 13010 SHIFT GUIDE HOUSING GASKET Replaces: 25142-94560</p> |
|---|---|--|---|











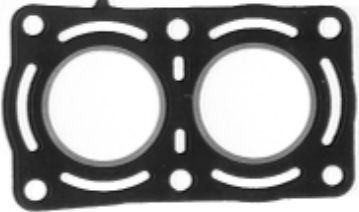

| | | | |
|---|---|--|--|
|  <p>18-8342 SEAL RING GASKET Replaces: 55122-94400</p> |  <p>18-8343 SEAL RING GASKET Replaces: 55122-95201</p> |  <p>18-8344 SEAL RING GASKET Replaces: 55122-95500</p> |  <p>18-8331 DRAIN PLUG GASKET Replaces: 09168-10022</p> |
|---|---|--|--|

| HP/Model | Year | Sierra Impeller | AP Impeller | Sierra Gasket | AP Gasket | HP/Model | Year | Sierra Impeller | AP Impeller | Sierra Gasket | AP Gasket |
|----------|---------|-----------------|-------------|---------------|-----------|------------|------------|-----------------|-------------|---------------|-----------|
| DT5 | 1977-83 | 18-3097 | 13154 | — | — | DT35 | 1987-89 | 18-3096 | 13153 | 18-0461 | 2868 |
| DT6 | 1984-98 | 18-3097 | 13154 | — | — | DT40 | 1980-83 | 18-3094 | 2176 | 18-0459 | 2877 |
| DT8 | 1980-87 | 18-3097 | 13154 | — | — | DT40/DT40C | 1984-98 | 18-3096 | 13153 | 18-0461 | 2868 |
| DT9.9 | 1977-82 | 18-3092 | 13151 | — | — | PU40 (jet) | 1989-94 | 18-3096 | 13153 | 18-0461 | 2868 |
| DT9.9 | 1983-87 | 18-3093 | 13152 | — | — | DT50 | 1982-prior | 18-3094 | 2176 | 18-0459 | 2877 |
| DT9.9 | 1997-98 | 18-3093 | 13152 | — | — | DT50 | 1983 | 18-3094 | 2176 | 18-0460 | 2876 |
| DT14 | 1977-80 | 18-3092 | 13151 | — | — | DT50 | 1984 | 18-3095 | 2177 | 18-0460 | 2876 |
| DT15 | 1983-88 | 18-3093 | 13152 | — | — | DT50M | 1980-84 | 18-3094 | 2176 | 18-0460 | 2876 |
| DT15C | 1989-97 | 18-3093 | 13152 | — | — | DT55 | 1985-97 | 18-3094 | 2176 | 18-0460 | 2876 |
| DF15 | 1997-98 | 18-3093 | 13152 | — | — | PU55 (jet) | 1989-94 | 18-3094 | 2176 | 18-0460 | 2876 |
| DT16 | 1977-82 | 18-3092 | 13151 | — | — | DT60 | 1983 | 18-3094 | 2176 | 18-0460 | 2876 |
| DT20 | 1986-88 | 18-3096 | 13153 | 18-0461 | 2868 | DT60 | 1984 | 18-3096 | 13153 | 18-0460 | 2876 |
| DT25 | 1980-82 | 18-3092 | 13151 | — | — | DT65 | 1982-prior | 18-3094 | 2176 | 18-0459 | 2877 |
| DT25 | 1983-88 | 18-3096 | 13153 | 18-0461 | 2868 | DT65 | 1985-97 | 18-3096 | 13153 | 18-0460 | 2876 |
| DT30 | 1983-87 | 18-3096 | 13153 | 18-0461 | 2868 | DT75 | 1983-97 | 18-3095 | 2177 | 18-0459 | 2877 |
| DT35 | 1980-82 | 18-3094 | 2176 | 18-0459 | 2877 | DT85 | 1980-97 | 18-3095 | 2177 | 18-0459 | 2877 |
| | | | | | | PU85 (jet) | 1989-97 | 18-3095 | 2177 | 18-0459 | 2877 |

| | | | |
|--|--|---|--|
|  <p>18-3806 HEAD GASKET Replaces: 11141-98401</p> |  <p>18-3807 AP# 13216 HEAD GASKET Replaces: 11141-98101</p> |  <p>18-3808 AP# 13217 HEAD GASKET Replaces: 11141-93901</p> |  <p>18-3809 AP# 13218 HEAD GASKET Replaces: 11141-96303</p> |
|--|--|---|--|

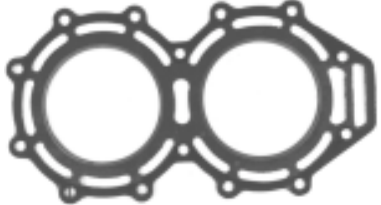

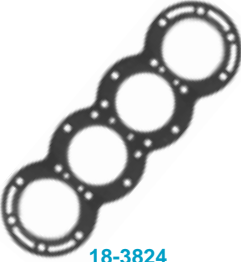
| | | | |
|--|--|---|--|
|  <p>18-3810 AP# 13219 HEAD GASKET Replaces: 11141-94401</p> |  <p>18-3811 AP# 13220 HEAD GASKET Replaces: 11141-94303</p> |  <p>18-3812 AP# 13221 HEAD GASKET Replaces: 11141-95206</p> |  <p>18-3813 AP# 13222 HEAD GASKET Replaces: 11141-95305</p> |
|--|--|---|--|

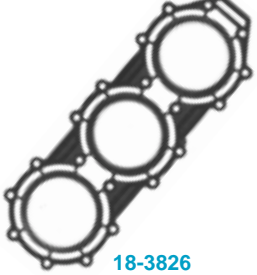
OUTBOARD

| | | | |
|--|---|--|--|
|  18-3814 AP# 13223 HEAD GASKET Replaces: 11141-95505 |  18-3815 AP# 13224 HEAD GASKET Replaces: 11141-98300 |  18-3816 AP# 13225 HEAD GASKET Replaces: 11141-98504 | |
|  18-3817 AP# 13226 HEAD GASKET Replaces: 11141-92D01 |  18-3818 AP# 13227 HEAD GASKET Replaces: 11141-96311 |  18-3819 AP# 13228 HEAD GASKET Replaces: 11141-95D90 | |
|  18-3820 HEAD GASKET Replaces: 11141-94701 |  18-3821 HEAD GASKET Replaces: 11141-95600 |  18-3822 HEAD GASKET Replaces: 11141-87E90 | |
|  18-3823 HEAD GASKET Replaces: 11141-94506 |  18-3824 HEAD GASKET Replaces: 11141-94600 |  18-3825 HEAD GASKET Replaces: 11141-87D90 |  18-3826 HEAD GASKET Replaces: 11141-87D92 |

OUTBOARD

| Model | Year | Cyl | Head Gasket | Model | Year | Cyl | Head Gasket | Model | Year | Cyl | Head Gasket |
|-------|---------|-----|-------------|-------|---------|-----|-------------|-------|---------|-----|-------------|
| 2 | 1983-89 | 1 | 18-3806 | 30 | 1983-87 | 2 | 18-3809 | 85 | 1983-87 | 3 | 18-3814 |
| 3.5 | 1983-84 | 1 | 18-3815 | 30 | 1988-89 | 3 | 18-3819 | 85 | 1988-89 | 3 | 18-3821 |
| 5 | 1983 | 2 | 18-3816 | 35 | 1987-89 | 2 | 18-3810 | 90 | 1989 | V-4 | 18-3822 |
| 6 | 1984-89 | 2 | 18-3807 | 40 | 1983 | 2 | 18-3811 | 100 | 1989 | V-4 | 18-3822 |
| 8 | 1983-87 | 2 | 18-3807 | 40 | 1984-89 | 2 | 18-3810 | 115 | 1983-85 | 4 | 18-3823 |
| 8 | 1988-89 | 2 | 18-3817 | 50 | 1983 | 2 | 18-3812 | 115 | 1986-89 | 4 | 18-3824 |
| 9.9 | 1983-87 | 2 | 18-3808 | 50M | 1983-84 | 2 | 18-3812 | 140 | 1983-85 | 4 | 18-3823 |
| 9.9 | 1988-89 | 2 | 18-3817 | 50 | 1984 | 2 | 18-3813 | 140 | 1986-89 | 4 | 18-3824 |
| 15 | 1983-89 | 2 | 18-3808 | 55 | 1985-89 | 3 | 18-3820 | 150 | 1986 | V-6 | 18-3825 |
| 20 | 1986-88 | 2 | 18-3818 | 65 | 1985-89 | 3 | 18-3820 | 150 | 1987-89 | V-6 | 18-3826 |
| 25 | 1983-88 | 2 | 18-3809 | 75 | 1983-87 | 3 | 18-3814 | 175 | 1987-89 | V-6 | 18-3826 |
| 25 | 1989 | 3 | 18-3819 | 75 | 1988-89 | 3 | 18-3821 | 200 | 1986 | V-6 | 18-3825 |
| | | | | | | | | 200 | 1987-89 | V-6 | 18-3826 |

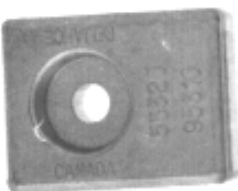
|  <p>18-8327 SHIFT SHAFT SEAL Replaces: 09284-08003</p> |  <p>18-8328 SHIFT SHAFT SEAL Replaces: 09284-08005</p> |  <p>18-8334 SHIFT SHAFT SEAL Replaces: 25223-94400</p> |  <p>18-7903 OIL FILTER Replaces: 16510-05240 FOR: DF9.9, DF15</p> |  <p>18-7915 OIL FILTER Replaces: 16510-87J00, 16510-82703 For: DF25,DF30,DF40,DF50, DF60, DF70, DF400,DF500, 4-stroke</p> | | | | | | | | | | | | | | | | | | | | | | | | | | | | | | | | | | | | | | | | | | | | | | | | | | | | | | | | | | |
|---|--|--|---|--|---------|------------|-------------|-------------|---|---------|-----------------------------|--|---------|-------------|-----------------------|---------|-------------|--|-------------|-------------|--|----------|-------------|--|-------------|---------|--------|-------------|----------|---------|-------------|-----------------------------|------------|------|-----------------------------|-------------|--------|---------|-------------|-------------|---------|--|-------------|--------|--------|-------------|---------|------|-----------------------------|------------|---|---|-------------|--------|---------|---|-------------|----------|---------|---|-------------|--------|
|  <p>18-3726 AP# 1830 PROP NUT Replaces: 09141-18005</p> |  <p>18-3710 PROP NUT Replaces: 09141-14008</p> |  <p>SPACER</p> <table border="1"> <thead> <tr> <th>Model</th> <th>Sierra #</th> <th>O.E. #</th> </tr> </thead> <tbody> <tr> <td>DT40/55/65</td> <td>18-3794</td> <td>57633-94300</td> </tr> <tr> <td>V-6</td> <td>18-3795</td> <td>57633-87D30</td> </tr> <tr> <td>DT9.9/15C/DF9.9/15</td> <td>18-3796</td> <td>57633-93900</td> </tr> <tr> <td>DT8/9.9C Oil Injected</td> <td>18-3797</td> <td>57633-92D00</td> </tr> <tr> <td>DT75/85/90/100/115/ 140 w. V style/ DF60/70 w. V style</td> <td>18-3798</td> <td>57633-94500</td> </tr> <tr> <td>DT20/25C/30C</td> <td>18-3799</td> <td>57630-96300</td> </tr> </tbody> </table> | Model | Sierra # | O.E. # | DT40/55/65 | 18-3794 | 57633-94300 | V-6 | 18-3795 | 57633-87D30 | DT9.9/15C/DF9.9/15 | 18-3796 | 57633-93900 | DT8/9.9C Oil Injected | 18-3797 | 57633-92D00 | DT75/85/90/100/115/ 140 w. V style/ DF60/70 w. V style | 18-3798 | 57633-94500 | DT20/25C/30C | 18-3799 | 57630-96300 |  <p>18-3774 PROP NUT KIT Replaces: 57630-94500 For: DT75/85/90/100/115, 140 with V-Style, DF60/70 with V Style</p> <table border="1"> <thead> <tr> <th>Sierra #</th> <th>AP #</th> <th>O.E. #</th> <th>Desc.</th> </tr> </thead> <tbody> <tr> <td>18-3726</td> <td>1830</td> <td>09141-18005</td> <td>Prop Nut</td> </tr> <tr> <td>18-3735</td> <td>1832</td> <td>09204-03003, 09204-03004</td> <td>Cotter Pin</td> </tr> <tr> <td>—</td> <td>—</td> <td>09160-18028</td> <td>Washer</td> </tr> <tr> <td>18-3798</td> <td>—</td> <td>57633-94500</td> <td>Spacer</td> </tr> </tbody> </table> | Sierra # | AP # | O.E. # | Desc. | 18-3726 | 1830 | 09141-18005 | Prop Nut | 18-3735 | 1832 | 09204-03003, 09204-03004 | Cotter Pin | — | — | 09160-18028 | Washer | 18-3798 | — | 57633-94500 | Spacer | | | | | | | | | | | | | | | | | | |
| Model | Sierra # | O.E. # | | | | | | | | | | | | | | | | | | | | | | | | | | | | | | | | | | | | | | | | | | | | | | | | | | | | | | | | | | | | |
| DT40/55/65 | 18-3794 | 57633-94300 | | | | | | | | | | | | | | | | | | | | | | | | | | | | | | | | | | | | | | | | | | | | | | | | | | | | | | | | | | | | |
| V-6 | 18-3795 | 57633-87D30 | | | | | | | | | | | | | | | | | | | | | | | | | | | | | | | | | | | | | | | | | | | | | | | | | | | | | | | | | | | | |
| DT9.9/15C/DF9.9/15 | 18-3796 | 57633-93900 | | | | | | | | | | | | | | | | | | | | | | | | | | | | | | | | | | | | | | | | | | | | | | | | | | | | | | | | | | | | |
| DT8/9.9C Oil Injected | 18-3797 | 57633-92D00 | | | | | | | | | | | | | | | | | | | | | | | | | | | | | | | | | | | | | | | | | | | | | | | | | | | | | | | | | | | | |
| DT75/85/90/100/115/ 140 w. V style/ DF60/70 w. V style | 18-3798 | 57633-94500 | | | | | | | | | | | | | | | | | | | | | | | | | | | | | | | | | | | | | | | | | | | | | | | | | | | | | | | | | | | | |
| DT20/25C/30C | 18-3799 | 57630-96300 | | | | | | | | | | | | | | | | | | | | | | | | | | | | | | | | | | | | | | | | | | | | | | | | | | | | | | | | | | | | |
| Sierra # | AP # | O.E. # | Desc. | | | | | | | | | | | | | | | | | | | | | | | | | | | | | | | | | | | | | | | | | | | | | | | | | | | | | | | | | | | |
| 18-3726 | 1830 | 09141-18005 | Prop Nut | | | | | | | | | | | | | | | | | | | | | | | | | | | | | | | | | | | | | | | | | | | | | | | | | | | | | | | | | | | |
| 18-3735 | 1832 | 09204-03003, 09204-03004 | Cotter Pin | | | | | | | | | | | | | | | | | | | | | | | | | | | | | | | | | | | | | | | | | | | | | | | | | | | | | | | | | | | |
| — | — | 09160-18028 | Washer | | | | | | | | | | | | | | | | | | | | | | | | | | | | | | | | | | | | | | | | | | | | | | | | | | | | | | | | | | | |
| 18-3798 | — | 57633-94500 | Spacer | | | | | | | | | | | | | | | | | | | | | | | | | | | | | | | | | | | | | | | | | | | | | | | | | | | | | | | | | | | |
|  <p>18-3775 PROP NUT KIT Replaces: 57630-92E00 For: V-6</p> <p>— CONTAINS —</p> <table border="1"> <thead> <tr> <th>Sierra #</th> <th>AP #</th> <th>O.E. #</th> <th>Description</th> </tr> </thead> <tbody> <tr> <td>18-3726</td> <td>1830</td> <td>09141-18005</td> <td>Prop Nut</td> </tr> <tr> <td>18-3735</td> <td>1832</td> <td>09204-03003, 09204-03004</td> <td>Cotter Pin</td> </tr> <tr> <td>—</td> <td>—</td> <td>09160-18019</td> <td>Washer</td> </tr> <tr> <td>18-3795</td> <td>—</td> <td>57633-87D30</td> <td>Spacer</td> </tr> </tbody> </table> | Sierra # | AP # | O.E. # | Description | 18-3726 | 1830 | 09141-18005 | Prop Nut | 18-3735 | 1832 | 09204-03003, 09204-03004 | Cotter Pin | — | — | 09160-18019 | Washer | 18-3795 | — | 57633-87D30 | Spacer |  <p>18-3777 PROP NUT KIT Replaces: 57630-94300 For: DT40/55/65</p> <p>— CONTAINS —</p> <table border="1"> <thead> <tr> <th>Sierra #</th> <th>AP #</th> <th>O.E. #</th> <th>Description</th> </tr> </thead> <tbody> <tr> <td>18-3726</td> <td>1830</td> <td>09141-18005</td> <td>Prop Nut</td> </tr> <tr> <td>18-3735</td> <td>1832</td> <td>09204-03003, 09204-03004</td> <td>Cotter Pin</td> </tr> <tr> <td>—</td> <td>—</td> <td>09160-18028</td> <td>Washer</td> </tr> <tr> <td>18-3794</td> <td>—</td> <td>57633-94300</td> <td>Spacer</td> </tr> </tbody> </table> | Sierra # | AP # | O.E. # | Description | 18-3726 | 1830 | 09141-18005 | Prop Nut | 18-3735 | 1832 | 09204-03003, 09204-03004 | Cotter Pin | — | — | 09160-18028 | Washer | 18-3794 | — | 57633-94300 | Spacer |  <p>18-3778 PROP NUT KIT Replaces: 57630-96300 For: DT20/25C/30C</p> <p>— CONTAINS —</p> <table border="1"> <thead> <tr> <th>Sierra #</th> <th>AP #</th> <th>O.E. #</th> <th>Description</th> </tr> </thead> <tbody> <tr> <td>18-3735</td> <td>1832</td> <td>09204-03003, 09204-03004</td> <td>Cotter Pin</td> </tr> <tr> <td>—</td> <td>—</td> <td>09160-14028</td> <td>Washer</td> </tr> <tr> <td>18-3710</td> <td>—</td> <td>09141-14008</td> <td>Prop Nut</td> </tr> <tr> <td>18-3799</td> <td>—</td> <td>57633-96300</td> <td>Spacer</td> </tr> </tbody> </table> | Sierra # | AP # | O.E. # | Description | 18-3735 | 1832 | 09204-03003, 09204-03004 | Cotter Pin | — | — | 09160-14028 | Washer | 18-3710 | — | 09141-14008 | Prop Nut | 18-3799 | — | 57633-96300 | Spacer |
| Sierra # | AP # | O.E. # | Description | | | | | | | | | | | | | | | | | | | | | | | | | | | | | | | | | | | | | | | | | | | | | | | | | | | | | | | | | | | |
| 18-3726 | 1830 | 09141-18005 | Prop Nut | | | | | | | | | | | | | | | | | | | | | | | | | | | | | | | | | | | | | | | | | | | | | | | | | | | | | | | | | | | |
| 18-3735 | 1832 | 09204-03003, 09204-03004 | Cotter Pin | | | | | | | | | | | | | | | | | | | | | | | | | | | | | | | | | | | | | | | | | | | | | | | | | | | | | | | | | | | |
| — | — | 09160-18019 | Washer | | | | | | | | | | | | | | | | | | | | | | | | | | | | | | | | | | | | | | | | | | | | | | | | | | | | | | | | | | | |
| 18-3795 | — | 57633-87D30 | Spacer | | | | | | | | | | | | | | | | | | | | | | | | | | | | | | | | | | | | | | | | | | | | | | | | | | | | | | | | | | | |
| Sierra # | AP # | O.E. # | Description | | | | | | | | | | | | | | | | | | | | | | | | | | | | | | | | | | | | | | | | | | | | | | | | | | | | | | | | | | | |
| 18-3726 | 1830 | 09141-18005 | Prop Nut | | | | | | | | | | | | | | | | | | | | | | | | | | | | | | | | | | | | | | | | | | | | | | | | | | | | | | | | | | | |
| 18-3735 | 1832 | 09204-03003, 09204-03004 | Cotter Pin | | | | | | | | | | | | | | | | | | | | | | | | | | | | | | | | | | | | | | | | | | | | | | | | | | | | | | | | | | | |
| — | — | 09160-18028 | Washer | | | | | | | | | | | | | | | | | | | | | | | | | | | | | | | | | | | | | | | | | | | | | | | | | | | | | | | | | | | |
| 18-3794 | — | 57633-94300 | Spacer | | | | | | | | | | | | | | | | | | | | | | | | | | | | | | | | | | | | | | | | | | | | | | | | | | | | | | | | | | | |
| Sierra # | AP # | O.E. # | Description | | | | | | | | | | | | | | | | | | | | | | | | | | | | | | | | | | | | | | | | | | | | | | | | | | | | | | | | | | | |
| 18-3735 | 1832 | 09204-03003, 09204-03004 | Cotter Pin | | | | | | | | | | | | | | | | | | | | | | | | | | | | | | | | | | | | | | | | | | | | | | | | | | | | | | | | | | | |
| — | — | 09160-14028 | Washer | | | | | | | | | | | | | | | | | | | | | | | | | | | | | | | | | | | | | | | | | | | | | | | | | | | | | | | | | | | |
| 18-3710 | — | 09141-14008 | Prop Nut | | | | | | | | | | | | | | | | | | | | | | | | | | | | | | | | | | | | | | | | | | | | | | | | | | | | | | | | | | | |
| 18-3799 | — | 57633-96300 | Spacer | | | | | | | | | | | | | | | | | | | | | | | | | | | | | | | | | | | | | | | | | | | | | | | | | | | | | | | | | | | |
|  <p>18-6032 ANODE Replaces: 55320-95310 55-140 H.P.</p> |  <p>18-6033 TRIM TAB Replaces: 55125-87D00 150-200 H.P.</p> |  <p>18-6098 AP# 13417 TRIM TAB Replaces: 55125-96310</p> | <p>PKG. OF 10</p>  <p>COTTER PINS</p> <table border="1"> <thead> <tr> <th>Sierra #</th> <th>AP #</th> <th>Replaces</th> </tr> </thead> <tbody> <tr> <td>18-3737</td> <td>—</td> <td>29204-09204 For: DT9.9 & 15C, DF9.9 & 15, 8 & 9.9C (Oil Injected)</td> </tr> <tr> <td>18-3738</td> <td>1832</td> <td>09204-03003, 09204-03004 For: DT20, 25C, 30C</td> </tr> </tbody> </table> | Sierra # | AP # | Replaces | 18-3737 | — | 29204-09204 For: DT9.9 & 15C, DF9.9 & 15, 8 & 9.9C (Oil Injected) | 18-3738 | 1832 | 09204-03003, 09204-03004 For: DT20, 25C, 30C | | | | | | | | | | | | | | | | | | | | | | | | | | | | | | | | | | | | | | | | | | | | | | | | | | |
| Sierra # | AP # | Replaces | | | | | | | | | | | | | | | | | | | | | | | | | | | | | | | | | | | | | | | | | | | | | | | | | | | | | | | | | | | | |
| 18-3737 | — | 29204-09204 For: DT9.9 & 15C, DF9.9 & 15, 8 & 9.9C (Oil Injected) | | | | | | | | | | | | | | | | | | | | | | | | | | | | | | | | | | | | | | | | | | | | | | | | | | | | | | | | | | | | |
| 18-3738 | 1832 | 09204-03003, 09204-03004 For: DT20, 25C, 30C | | | | | | | | | | | | | | | | | | | | | | | | | | | | | | | | | | | | | | | | | | | | | | | | | | | | | | | | | | | | |

OUTBOARD



Lower Unit Seal Kits



Features...

- ★ Seals and o-rings designed to provide excellent performance in the harsh marine environment.
- ★ Kits include all necessary parts to do a complete reseal.
- ★ Easy quick reference application chart in our catalog.

| <p>18-8333 AP# 13546 LOWER UNIT SEAL KIT Replaces: 25700-87D00</p> <p>— CONTAINS —</p> <table border="1"> <thead> <tr> <th>Sierra #</th> <th>AP#</th> <th>Description</th> <th>O.E. #</th> <th>Qty.</th> </tr> </thead> <tbody> <tr><td>18-0456</td><td>13003</td><td>Water Pump Gasket</td><td>17472-87D10</td><td>1</td></tr> <tr><td>18-7118</td><td>—</td><td>O-Ring</td><td>09280-08008</td><td>1</td></tr> <tr><td>18-7183</td><td>1205</td><td>O-Ring</td><td>09280-69001</td><td>2</td></tr> <tr><td>18-7325</td><td>—</td><td>Seal</td><td>09282-30006</td><td>1</td></tr> <tr><td>18-7422</td><td>—</td><td>O-Ring</td><td>09280-20004</td><td>1</td></tr> <tr><td>18-7504</td><td>—</td><td>O-Ring</td><td>09280-55002</td><td>2</td></tr> <tr><td>18-8322</td><td>—</td><td>Seal</td><td>09282-24004</td><td>1</td></tr> <tr><td>18-8328</td><td>—</td><td>Shift Shaft Seal</td><td>09284-08005</td><td>2</td></tr> <tr><td>18-8331</td><td>13545</td><td>Drain Plug Gasket</td><td>09168-10022</td><td>2</td></tr> </tbody> </table> | | Sierra # | AP# | Description | O.E. # | Qty. | 18-0456 | 13003 | Water Pump Gasket | 17472-87D10 | 1 | 18-7118 | — | O-Ring | 09280-08008 | 1 | 18-7183 | 1205 | O-Ring | 09280-69001 | 2 | 18-7325 | — | Seal | 09282-30006 | 1 | 18-7422 | — | O-Ring | 09280-20004 | 1 | 18-7504 | — | O-Ring | 09280-55002 | 2 | 18-8322 | — | Seal | 09282-24004 | 1 | 18-8328 | — | Shift Shaft Seal | 09284-08005 | 2 | 18-8331 | 13545 | Drain Plug Gasket | 09168-10022 | 2 | <p>18-8336 AP# 13547 LOWER UNIT SEAL KIT Replaces: 25700-87E00</p> <p>— CONTAINS —</p> <table border="1"> <thead> <tr> <th>Sierra #</th> <th>AP#</th> <th>Description</th> <th>O.E. #</th> <th>Qty.</th> </tr> </thead> <tbody> <tr><td>18-0457</td><td>13004</td><td>Water Pump Gasket</td><td>17472-87E10</td><td>1</td></tr> <tr><td>18-7118</td><td>—</td><td>O-Ring</td><td>09280-08008</td><td>1</td></tr> <tr><td>18-7127</td><td>260</td><td>O-Ring</td><td>09280-86001</td><td>1</td></tr> <tr><td>18-7183</td><td>1205</td><td>O-Ring</td><td>09280-69001</td><td>1</td></tr> <tr><td>18-7422</td><td>—</td><td>O-Ring</td><td>09280-20004</td><td>1</td></tr> <tr><td>18-7503</td><td>—</td><td>O-Ring</td><td>09280-46004</td><td>1</td></tr> <tr><td>18-8320</td><td>—</td><td>Seal</td><td>09282-22004</td><td>2</td></tr> <tr><td>18-8324</td><td>—</td><td>Seal</td><td>09282-28003</td><td>2</td></tr> <tr><td>18-8328</td><td>—</td><td>Shift Shaft Seal</td><td>09284-08005</td><td>1</td></tr> <tr><td>18-8331</td><td>13545</td><td>Drain Plug Gasket</td><td>09168-10022</td><td>3</td></tr> </tbody> </table> | | Sierra # | AP# | Description | O.E. # | Qty. | 18-0457 | 13004 | Water Pump Gasket | 17472-87E10 | 1 | 18-7118 | — | O-Ring | 09280-08008 | 1 | 18-7127 | 260 | O-Ring | 09280-86001 | 1 | 18-7183 | 1205 | O-Ring | 09280-69001 | 1 | 18-7422 | — | O-Ring | 09280-20004 | 1 | 18-7503 | — | O-Ring | 09280-46004 | 1 | 18-8320 | — | Seal | 09282-22004 | 2 | 18-8324 | — | Seal | 09282-28003 | 2 | 18-8328 | — | Shift Shaft Seal | 09284-08005 | 1 | 18-8331 | 13545 | Drain Plug Gasket | 09168-10022 | 3 |
|---|-------|-------------------|-------------|-------------|--------|------|---------|-------|-------------------|-------------|---|---------|-----|--------|-------------|---|---------|------|--------|-------------|---|---------|---|--------|-------------|---|---------|---|--------|-------------|---|---------|-------|-------------------|-------------|---|---------|---|------------------|-------------|---|---------|---|------------------|-------------|---|---------|-------|-------------------|-------------|---|---|--|----------|-----|-------------|--------|------|---------|-------|-------------------|-------------|---|---------|-------|-------------------|-------------|---|---------|-------|--------|-------------|---|---------|-------|--------|-------------|---|---------|---|--------|-------------|---|---------|------|--------|-------------|---|---------|---|------|-------------|---|---------|---|------|-------------|---|---------|---|------------------|-------------|---|---------|-------|-------------------|-------------|---|
| Sierra # | AP# | Description | O.E. # | Qty. | | | | | | | | | | | | | | | | | | | | | | | | | | | | | | | | | | | | | | | | | | | | | | | | | | | | | | | | | | | | | | | | | | | | | | | | | | | | | | | | | | | | | | | | | | | | | | | | | | | | | | | | |
| 18-0456 | 13003 | Water Pump Gasket | 17472-87D10 | 1 | | | | | | | | | | | | | | | | | | | | | | | | | | | | | | | | | | | | | | | | | | | | | | | | | | | | | | | | | | | | | | | | | | | | | | | | | | | | | | | | | | | | | | | | | | | | | | | | | | | | | | | | |
| 18-7118 | — | O-Ring | 09280-08008 | 1 | | | | | | | | | | | | | | | | | | | | | | | | | | | | | | | | | | | | | | | | | | | | | | | | | | | | | | | | | | | | | | | | | | | | | | | | | | | | | | | | | | | | | | | | | | | | | | | | | | | | | | | | |
| 18-7183 | 1205 | O-Ring | 09280-69001 | 2 | | | | | | | | | | | | | | | | | | | | | | | | | | | | | | | | | | | | | | | | | | | | | | | | | | | | | | | | | | | | | | | | | | | | | | | | | | | | | | | | | | | | | | | | | | | | | | | | | | | | | | | | |
| 18-7325 | — | Seal | 09282-30006 | 1 | | | | | | | | | | | | | | | | | | | | | | | | | | | | | | | | | | | | | | | | | | | | | | | | | | | | | | | | | | | | | | | | | | | | | | | | | | | | | | | | | | | | | | | | | | | | | | | | | | | | | | | | |
| 18-7422 | — | O-Ring | 09280-20004 | 1 | | | | | | | | | | | | | | | | | | | | | | | | | | | | | | | | | | | | | | | | | | | | | | | | | | | | | | | | | | | | | | | | | | | | | | | | | | | | | | | | | | | | | | | | | | | | | | | | | | | | | | | | |
| 18-7504 | — | O-Ring | 09280-55002 | 2 | | | | | | | | | | | | | | | | | | | | | | | | | | | | | | | | | | | | | | | | | | | | | | | | | | | | | | | | | | | | | | | | | | | | | | | | | | | | | | | | | | | | | | | | | | | | | | | | | | | | | | | | |
| 18-8322 | — | Seal | 09282-24004 | 1 | | | | | | | | | | | | | | | | | | | | | | | | | | | | | | | | | | | | | | | | | | | | | | | | | | | | | | | | | | | | | | | | | | | | | | | | | | | | | | | | | | | | | | | | | | | | | | | | | | | | | | | | |
| 18-8328 | — | Shift Shaft Seal | 09284-08005 | 2 | | | | | | | | | | | | | | | | | | | | | | | | | | | | | | | | | | | | | | | | | | | | | | | | | | | | | | | | | | | | | | | | | | | | | | | | | | | | | | | | | | | | | | | | | | | | | | | | | | | | | | | | |
| 18-8331 | 13545 | Drain Plug Gasket | 09168-10022 | 2 | | | | | | | | | | | | | | | | | | | | | | | | | | | | | | | | | | | | | | | | | | | | | | | | | | | | | | | | | | | | | | | | | | | | | | | | | | | | | | | | | | | | | | | | | | | | | | | | | | | | | | | | |
| Sierra # | AP# | Description | O.E. # | Qty. | | | | | | | | | | | | | | | | | | | | | | | | | | | | | | | | | | | | | | | | | | | | | | | | | | | | | | | | | | | | | | | | | | | | | | | | | | | | | | | | | | | | | | | | | | | | | | | | | | | | | | | | |
| 18-0457 | 13004 | Water Pump Gasket | 17472-87E10 | 1 | | | | | | | | | | | | | | | | | | | | | | | | | | | | | | | | | | | | | | | | | | | | | | | | | | | | | | | | | | | | | | | | | | | | | | | | | | | | | | | | | | | | | | | | | | | | | | | | | | | | | | | | |
| 18-7118 | — | O-Ring | 09280-08008 | 1 | | | | | | | | | | | | | | | | | | | | | | | | | | | | | | | | | | | | | | | | | | | | | | | | | | | | | | | | | | | | | | | | | | | | | | | | | | | | | | | | | | | | | | | | | | | | | | | | | | | | | | | | |
| 18-7127 | 260 | O-Ring | 09280-86001 | 1 | | | | | | | | | | | | | | | | | | | | | | | | | | | | | | | | | | | | | | | | | | | | | | | | | | | | | | | | | | | | | | | | | | | | | | | | | | | | | | | | | | | | | | | | | | | | | | | | | | | | | | | | |
| 18-7183 | 1205 | O-Ring | 09280-69001 | 1 | | | | | | | | | | | | | | | | | | | | | | | | | | | | | | | | | | | | | | | | | | | | | | | | | | | | | | | | | | | | | | | | | | | | | | | | | | | | | | | | | | | | | | | | | | | | | | | | | | | | | | | | |
| 18-7422 | — | O-Ring | 09280-20004 | 1 | | | | | | | | | | | | | | | | | | | | | | | | | | | | | | | | | | | | | | | | | | | | | | | | | | | | | | | | | | | | | | | | | | | | | | | | | | | | | | | | | | | | | | | | | | | | | | | | | | | | | | | | |
| 18-7503 | — | O-Ring | 09280-46004 | 1 | | | | | | | | | | | | | | | | | | | | | | | | | | | | | | | | | | | | | | | | | | | | | | | | | | | | | | | | | | | | | | | | | | | | | | | | | | | | | | | | | | | | | | | | | | | | | | | | | | | | | | | | |
| 18-8320 | — | Seal | 09282-22004 | 2 | | | | | | | | | | | | | | | | | | | | | | | | | | | | | | | | | | | | | | | | | | | | | | | | | | | | | | | | | | | | | | | | | | | | | | | | | | | | | | | | | | | | | | | | | | | | | | | | | | | | | | | | |
| 18-8324 | — | Seal | 09282-28003 | 2 | | | | | | | | | | | | | | | | | | | | | | | | | | | | | | | | | | | | | | | | | | | | | | | | | | | | | | | | | | | | | | | | | | | | | | | | | | | | | | | | | | | | | | | | | | | | | | | | | | | | | | | | |
| 18-8328 | — | Shift Shaft Seal | 09284-08005 | 1 | | | | | | | | | | | | | | | | | | | | | | | | | | | | | | | | | | | | | | | | | | | | | | | | | | | | | | | | | | | | | | | | | | | | | | | | | | | | | | | | | | | | | | | | | | | | | | | | | | | | | | | | |
| 18-8331 | 13545 | Drain Plug Gasket | 09168-10022 | 3 | | | | | | | | | | | | | | | | | | | | | | | | | | | | | | | | | | | | | | | | | | | | | | | | | | | | | | | | | | | | | | | | | | | | | | | | | | | | | | | | | | | | | | | | | | | | | | | | | | | | | | | | |
| <p>18-8337 AP# 13548 LOWER UNIT SEAL KIT Replaces: 25700-94400</p> <p>— CONTAINS —</p> <table border="1"> <thead> <tr> <th>Sierra #</th> <th>AP#</th> <th>Description</th> <th>O.E. #</th> <th>Qty.</th> </tr> </thead> <tbody> <tr><td>18-0461</td><td>2868</td><td>Water Pump Gasket</td><td>17472-96301</td><td>1</td></tr> <tr><td>18-7151</td><td>222</td><td>O-Ring</td><td>09280-75001</td><td>1</td></tr> <tr><td>18-7413</td><td>—</td><td>O-Ring</td><td>09280-08005</td><td>2</td></tr> <tr><td>18-7501</td><td>—</td><td>O-Ring</td><td>09280-11001</td><td>1</td></tr> <tr><td>18-8315</td><td>—</td><td>Seal</td><td>09282-17005</td><td>2</td></tr> <tr><td>18-8331</td><td>13545</td><td>Drain Plug Gasket</td><td>09168-10022</td><td>3</td></tr> <tr><td>18-8334</td><td>—</td><td>Shift Shaft Seal</td><td>25223-94400</td><td>1</td></tr> <tr><td>18-8342</td><td>—</td><td>Seal Ring</td><td>55122-94400</td><td>1</td></tr> <tr><td>18-8345</td><td>—</td><td>Seal</td><td>09289-22007</td><td>2</td></tr> </tbody> </table> | | Sierra # | AP# | Description | O.E. # | Qty. | 18-0461 | 2868 | Water Pump Gasket | 17472-96301 | 1 | 18-7151 | 222 | O-Ring | 09280-75001 | 1 | 18-7413 | — | O-Ring | 09280-08005 | 2 | 18-7501 | — | O-Ring | 09280-11001 | 1 | 18-8315 | — | Seal | 09282-17005 | 2 | 18-8331 | 13545 | Drain Plug Gasket | 09168-10022 | 3 | 18-8334 | — | Shift Shaft Seal | 25223-94400 | 1 | 18-8342 | — | Seal Ring | 55122-94400 | 1 | 18-8345 | — | Seal | 09289-22007 | 2 | <p>18-8338 AP# 13549 LOWER UNIT SEAL KIT Replaces: 25700-94500</p> <p>— CONTAINS —</p> <table border="1"> <thead> <tr> <th>Sierra #</th> <th>AP#</th> <th>Description</th> <th>O.E. #</th> <th>Qty.</th> </tr> </thead> <tbody> <tr><td>18-0268</td><td>—</td><td>O-Ring</td><td>09280-55002</td><td>1</td></tr> <tr><td>18-0458</td><td>13005</td><td>Water Pump Gasket</td><td>17472-94510</td><td>1</td></tr> <tr><td>18-0629</td><td>13009</td><td>Gasket</td><td>25142-94520</td><td>1</td></tr> <tr><td>18-0630</td><td>13010</td><td>Gasket</td><td>25142-94560</td><td>1</td></tr> <tr><td>18-7118</td><td>—</td><td>O-Ring</td><td>09280-08008</td><td>1</td></tr> <tr><td>18-7191</td><td>1217</td><td>O-Ring</td><td>09280-15003</td><td>1</td></tr> <tr><td>18-8321</td><td>—</td><td>Seal</td><td>09282-24003</td><td>2</td></tr> <tr><td>18-8323</td><td>—</td><td>Seal</td><td>09282-28002</td><td>2</td></tr> <tr><td>18-8327</td><td>—</td><td>Shift Shaft Seal</td><td>09284-08003</td><td>1</td></tr> <tr><td>18-8331</td><td>13545</td><td>Drain Plug Gasket</td><td>09168-10022</td><td>3</td></tr> </tbody> </table> | | Sierra # | AP# | Description | O.E. # | Qty. | 18-0268 | — | O-Ring | 09280-55002 | 1 | 18-0458 | 13005 | Water Pump Gasket | 17472-94510 | 1 | 18-0629 | 13009 | Gasket | 25142-94520 | 1 | 18-0630 | 13010 | Gasket | 25142-94560 | 1 | 18-7118 | — | O-Ring | 09280-08008 | 1 | 18-7191 | 1217 | O-Ring | 09280-15003 | 1 | 18-8321 | — | Seal | 09282-24003 | 2 | 18-8323 | — | Seal | 09282-28002 | 2 | 18-8327 | — | Shift Shaft Seal | 09284-08003 | 1 | 18-8331 | 13545 | Drain Plug Gasket | 09168-10022 | 3 |
| Sierra # | AP# | Description | O.E. # | Qty. | | | | | | | | | | | | | | | | | | | | | | | | | | | | | | | | | | | | | | | | | | | | | | | | | | | | | | | | | | | | | | | | | | | | | | | | | | | | | | | | | | | | | | | | | | | | | | | | | | | | | | | | |
| 18-0461 | 2868 | Water Pump Gasket | 17472-96301 | 1 | | | | | | | | | | | | | | | | | | | | | | | | | | | | | | | | | | | | | | | | | | | | | | | | | | | | | | | | | | | | | | | | | | | | | | | | | | | | | | | | | | | | | | | | | | | | | | | | | | | | | | | | |
| 18-7151 | 222 | O-Ring | 09280-75001 | 1 | | | | | | | | | | | | | | | | | | | | | | | | | | | | | | | | | | | | | | | | | | | | | | | | | | | | | | | | | | | | | | | | | | | | | | | | | | | | | | | | | | | | | | | | | | | | | | | | | | | | | | | | |
| 18-7413 | — | O-Ring | 09280-08005 | 2 | | | | | | | | | | | | | | | | | | | | | | | | | | | | | | | | | | | | | | | | | | | | | | | | | | | | | | | | | | | | | | | | | | | | | | | | | | | | | | | | | | | | | | | | | | | | | | | | | | | | | | | | |
| 18-7501 | — | O-Ring | 09280-11001 | 1 | | | | | | | | | | | | | | | | | | | | | | | | | | | | | | | | | | | | | | | | | | | | | | | | | | | | | | | | | | | | | | | | | | | | | | | | | | | | | | | | | | | | | | | | | | | | | | | | | | | | | | | | |
| 18-8315 | — | Seal | 09282-17005 | 2 | | | | | | | | | | | | | | | | | | | | | | | | | | | | | | | | | | | | | | | | | | | | | | | | | | | | | | | | | | | | | | | | | | | | | | | | | | | | | | | | | | | | | | | | | | | | | | | | | | | | | | | | |
| 18-8331 | 13545 | Drain Plug Gasket | 09168-10022 | 3 | | | | | | | | | | | | | | | | | | | | | | | | | | | | | | | | | | | | | | | | | | | | | | | | | | | | | | | | | | | | | | | | | | | | | | | | | | | | | | | | | | | | | | | | | | | | | | | | | | | | | | | | |
| 18-8334 | — | Shift Shaft Seal | 25223-94400 | 1 | | | | | | | | | | | | | | | | | | | | | | | | | | | | | | | | | | | | | | | | | | | | | | | | | | | | | | | | | | | | | | | | | | | | | | | | | | | | | | | | | | | | | | | | | | | | | | | | | | | | | | | | |
| 18-8342 | — | Seal Ring | 55122-94400 | 1 | | | | | | | | | | | | | | | | | | | | | | | | | | | | | | | | | | | | | | | | | | | | | | | | | | | | | | | | | | | | | | | | | | | | | | | | | | | | | | | | | | | | | | | | | | | | | | | | | | | | | | | | |
| 18-8345 | — | Seal | 09289-22007 | 2 | | | | | | | | | | | | | | | | | | | | | | | | | | | | | | | | | | | | | | | | | | | | | | | | | | | | | | | | | | | | | | | | | | | | | | | | | | | | | | | | | | | | | | | | | | | | | | | | | | | | | | | | |
| Sierra # | AP# | Description | O.E. # | Qty. | | | | | | | | | | | | | | | | | | | | | | | | | | | | | | | | | | | | | | | | | | | | | | | | | | | | | | | | | | | | | | | | | | | | | | | | | | | | | | | | | | | | | | | | | | | | | | | | | | | | | | | | |
| 18-0268 | — | O-Ring | 09280-55002 | 1 | | | | | | | | | | | | | | | | | | | | | | | | | | | | | | | | | | | | | | | | | | | | | | | | | | | | | | | | | | | | | | | | | | | | | | | | | | | | | | | | | | | | | | | | | | | | | | | | | | | | | | | | |
| 18-0458 | 13005 | Water Pump Gasket | 17472-94510 | 1 | | | | | | | | | | | | | | | | | | | | | | | | | | | | | | | | | | | | | | | | | | | | | | | | | | | | | | | | | | | | | | | | | | | | | | | | | | | | | | | | | | | | | | | | | | | | | | | | | | | | | | | | |
| 18-0629 | 13009 | Gasket | 25142-94520 | 1 | | | | | | | | | | | | | | | | | | | | | | | | | | | | | | | | | | | | | | | | | | | | | | | | | | | | | | | | | | | | | | | | | | | | | | | | | | | | | | | | | | | | | | | | | | | | | | | | | | | | | | | | |
| 18-0630 | 13010 | Gasket | 25142-94560 | 1 | | | | | | | | | | | | | | | | | | | | | | | | | | | | | | | | | | | | | | | | | | | | | | | | | | | | | | | | | | | | | | | | | | | | | | | | | | | | | | | | | | | | | | | | | | | | | | | | | | | | | | | | |
| 18-7118 | — | O-Ring | 09280-08008 | 1 | | | | | | | | | | | | | | | | | | | | | | | | | | | | | | | | | | | | | | | | | | | | | | | | | | | | | | | | | | | | | | | | | | | | | | | | | | | | | | | | | | | | | | | | | | | | | | | | | | | | | | | | |
| 18-7191 | 1217 | O-Ring | 09280-15003 | 1 | | | | | | | | | | | | | | | | | | | | | | | | | | | | | | | | | | | | | | | | | | | | | | | | | | | | | | | | | | | | | | | | | | | | | | | | | | | | | | | | | | | | | | | | | | | | | | | | | | | | | | | | |
| 18-8321 | — | Seal | 09282-24003 | 2 | | | | | | | | | | | | | | | | | | | | | | | | | | | | | | | | | | | | | | | | | | | | | | | | | | | | | | | | | | | | | | | | | | | | | | | | | | | | | | | | | | | | | | | | | | | | | | | | | | | | | | | | |
| 18-8323 | — | Seal | 09282-28002 | 2 | | | | | | | | | | | | | | | | | | | | | | | | | | | | | | | | | | | | | | | | | | | | | | | | | | | | | | | | | | | | | | | | | | | | | | | | | | | | | | | | | | | | | | | | | | | | | | | | | | | | | | | | |
| 18-8327 | — | Shift Shaft Seal | 09284-08003 | 1 | | | | | | | | | | | | | | | | | | | | | | | | | | | | | | | | | | | | | | | | | | | | | | | | | | | | | | | | | | | | | | | | | | | | | | | | | | | | | | | | | | | | | | | | | | | | | | | | | | | | | | | | |
| 18-8331 | 13545 | Drain Plug Gasket | 09168-10022 | 3 | | | | | | | | | | | | | | | | | | | | | | | | | | | | | | | | | | | | | | | | | | | | | | | | | | | | | | | | | | | | | | | | | | | | | | | | | | | | | | | | | | | | | | | | | | | | | | | | | | | | | | | | |

OUTBOARD

SEAL KIT APPLICATION ON NEXT PAGE

OUTBOARD

— CONTAINS —

| Sierra # | AP# | Description | O.E. # | Qty. |
|----------|-------|-------------------|-------------|------|
| 18-0460 | 2876 | Water Pump Gasket | 17472-95310 | 1 |
| 18-7151 | 222 | O-Ring | 09280-76006 | 1 |
| 18-7413 | — | O-Ring | 09280-08005 | 1 |
| 18-7501 | — | O-Ring | 09280-11001 | 1 |
| 18-8329 | — | Seal | 09289-17005 | 1 |
| 18-8331 | 13545 | Drain Plug Gasket | 09168-10022 | 3 |
| 18-8334 | — | Shift Shaft Seal | 25223-94400 | 1 |
| 18-8343 | 13553 | Seal Ring | 55122-95201 | 1 |
| 18-8345 | — | Seal | 09289-22007 | 2 |



18-8339
LOWER UNIT SEAL KIT
Replaces: 25700-94700

— CONTAINS —

| Sierra # | AP# | Description | O.E. # | Qty. |
|----------|-------|-------------------|-------------|------|
| 18-0459 | 2877 | Water Pump Gasket | 17472-95200 | 1 |
| 18-7413 | — | O-Ring | 09280-08005 | 1 |
| 18-7501 | — | O-Ring | 09280-11001 | 1 |
| 18-7506 | — | O-Ring | 09280-85001 | 1 |
| 18-8318 | — | Seal | 09282-20007 | 2 |
| 18-8319 | — | Seal | 09282-20008 | 2 |
| 18-8323 | — | Seal | 09282-28002 | 2 |
| 18-8331 | 13545 | Drain Plug Gasket | 09168-10022 | 3 |
| 18-8334 | — | Shift Shaft Seal | 25223-94400 | 1 |
| 18-8344 | 13554 | Seal Ring | 55122-95500 | 1 |

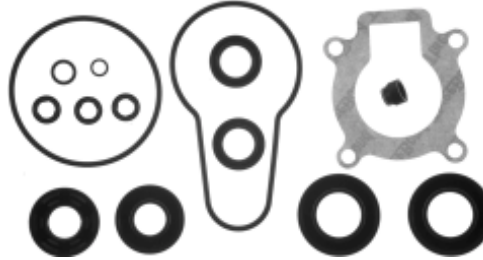

18-8340
LOWER UNIT SEAL KIT
Replaces: 25700-95500

— CONTAINS —

| Sierra # | AP# | Description | O.E. # | Qty. |
|----------|-------|-------------------|-------------|------|
| 18-0461 | 2868 | Water Pump Gasket | 17472-96301 | 1 |
| 18-7118 | — | O-Ring | 09280-50005 | 1 |
| 18-7413 | — | O-Ring | 09280-08005 | 1 |
| 18-7502 | — | O-Ring | 09280-13005 | 1 |
| 18-7505 | — | O-Ring | 09280-75002 | 1 |
| 18-7140 | — | Seal | 09282-17006 | 2 |
| 18-8317 | — | Seal | 09282-17007 | 2 |
| 18-8330 | — | Seal | 09289-20009 | 2 |
| 18-8331 | 13545 | Drain Plug Gasket | 09168-10022 | 3 |



18-8341
LOWER UNIT SEAL KIT
Replaces: 25700-95D00

| HP/Model | Year | Sierra # | AP # | HP/Model | Year | Sierra # | AP # | HP/Model | Year | Sierra # | AP # |
|----------|---------|----------|-------|----------|---------|----------|------|----------|---------|----------|-------|
| DT25C | 1989-98 | 18-8341 | — | DT55 | 1985-97 | 18-8339 | — | DT85 | 1985-98 | 18-8340 | — |
| DT30C | 1988-97 | 18-8341 | — | DT65 | 1985-97 | 18-8339 | — | DT90 | 1989-97 | 18-8336 | 13547 |
| DT40C | 1984-98 | 18-8337 | 13548 | DT75 | 1985-97 | 18-8340 | — | DT100 | 1989-98 | 18-8336 | 13547 |

PKG. OF 2

OIL SEALS

| Part # | O.E. # | I.D. | Dimensions O.D. (mm) | | Width |
|---------|-------------|-------|-------------------------|--|-------|
| 18-7325 | 09282-30006 | 3 | 45 | | 6 |
| 18-8315 | 09282-17005 | 17 | 32 | | 9 |
| 18-8316 | 09282-17006 | 17 | 30 | | 4.5 |
| 18-8317 | 09282-17007 | 17 | 28 | | 6 |
| 18-8318 | 09282-20007 | 20 | 42 | | 5.5 |
| 18-8319 | 09282-20008 | 20 | 32 | | 5 |
| 18-8320 | 09282-22004 | 22 | 36 | | 6 |
| 18-8321 | 09282-24003 | 25 | 36 | | 6 |
| 18-8322 | 09282-24004 | 24 | 40 | | 7 |
| 18-8323 | 09282-28002 | 28 | 50 | | 6 |
| 18-8324 | 09282-28003 | 28 | 42 | | 6 |
| 18-8329 | 09289-17005 | 15.85 | 35.10 | | 9 |
| 18-8330 | 09289-20009 | 20 | 34 | | 6.5 |
| 18-8345 | 09289-22007 | 22.2 | 35 | | 5 |

PKG. OF 5

O-RINGS

| Part No. | O.E. No. | Dimensions I. D. (mm) | | Width |
|----------|-------------|--------------------------|--|-------|
| 18-7118 | 09280-08008 | 69.40 | | 3.10 |
| 18-7501 | 09280-11001 | 11.00 | | 2.40 |
| 18-7502 | 09280-13005 | 13.00 | | 3.50 |
| 18-7503 | 09280-46004 | 46.00 | | 3.50 |
| 18-7504 | 09280-55002 | 55.00 | | 3.00 |
| 18-7140 | 09280-75002 | 69.00 | | 3.50 |
| 18-7506 | 09280-85001 | 86.00 | | 3.50 |