

COIL AND RESISTOR

Year	Model or Engine	Service Coil	Model or Engine	Service Coil
1969-70	Atomic Four w/o resistor	18-5435	Atomic Four w/resistor	18-5433
1948-70	12 Volt Ex Super Sabre	18-5435	Super Sabre	18-5433

PARTS FOR CHARGING SYSTEMS

PARTS FOR STARTING SYSTEMS

Year	Model	Volt	Alt. or Gen. No.	Voltage Regulator	Volt	Starter No.	Starter Switch Kit
1961-68	Explorer, Master, Super Six Unimite Four, Atomic Four, Utility Four, Blue Jacket Twin	-	-	-	12	MAU-4046	18-5840
		12	ALE-5202	18-5726	-	-	-
		12	ALE-5204S	18-5710	12	MAU-4006, 47	18-5840
		12	ALK-6204	18-5726 ①	12	MBG-4129, 31	18-5840
1955-68	Knight, Tarpon, Marlin, Bullet, Arrow, Bluefin	-	-	-	6	MAU-4046, 47	18-5840
1954-68	OK, OL, Z Superb, Z Series	-	-	-	6	MAU-4046, 47	18-5840
1961-64	11694 Super Sabre V-6	12	1100619, 54	18-5725	12	1107260	18-5804
1955-57	AMS, HCS, LHS	-	-	-	12	MAB-4116	18-5840

① For lead type, use 18-5340

















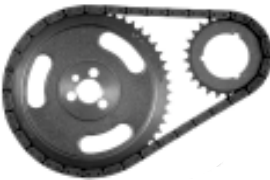





CARBURETOR KITS AND PARTS

Cyl.	Model or Engine	Carb Type and Model	Carb. No.	Sierra Carb. Kit	AP Carb. Kit
6	198(3.3L), 225(3.7L) E	R-2, 2GC	7023081,7025181	18-7070	3684
6	225(3.7L) Eng.	R-1, BC	7024083	18-7071	3620

THERMOSTAT

MISCELLANEOUS GASKETS

Description	O.E. #	AP Thermostat	Type	O.E. #	AP Gasket
Thermostat	275965	2459	Reverse Gear Cover	260040	2452
GASKET SETS			Exhaust Flange	260459	2440
			Exhaust Manifold	261050	2441
Type	O.E. #	AP Gasket Set	Thermostat	261601	2456
Overhaul	285608	2446	Head Gasket	263776	2447
Valve Grind	288517	2461	Carburetor Mounting	261202	2438
			Fuel Bowl	297339	2443

 <p>18-1400 HYDRAULIC ROLLER LIFTER Replaces: OMC & Volvo 3856127 Crusader 7231350 Mercruiser 17340 GM 4.3L/V-6 Late/5.0L/5.7L</p>	 <p>18-1401 HYDRAULIC LIFTER Replaces: Mercruiser 56153 OMC & Volvo 3853847 Ford 302/351 Ford 5.0L & 5.8L</p>	 <p>18-1402 HYDRAULIC LIFTER Replaces: Crusader 7230500 OMC & Volvo 3854033 Mercruiser 72638 GM 2.5L/120 GM 3.0L, 4.3L, 5.0L & 5.7L</p>	 <p>18-1403 HYDRAULIC LIFTER Replaces: Crusader 7230500 OMC 5232700 Mercruiser 93722,93722T 7.4L/454/8.2L/502</p>
 <p>18-1450 HI-PERFORMANCE TIMING KIT Replaces: Crusader 30267, 30268, 30269 Volvo & OMC 3891518, 3891517, 3891519 Mercruiser 77531, 7.4L/454</p>	 <p>18-1451 HI-PERFORMANCE TIMING KIT Replaces: OMC 464617, 340325, 14087014 Mercruiser 801798,4.3L/V-6 (Early)</p>	 <p>18-1452 HI-PERFORMANCE TIMING KIT Replaces: Mercruiser 801812 5.0L/5.7L/305</p>	 <p>18-1453 HI-PERFORMANCE TIMING KIT Replaces: OMC & Volvo 3856737 Mercruiser 801820, 5.0L/888 Ford 302</p>
 <p>18-1454 HI-PERFORMANCE TIMING KIT Replaces: Mercruiser 801871 4.3L/V-6 (Late)</p>	 <p>18-1455 HI-PERFORMANCE TIMING KIT Replaces: OMC 3909805, 3735402, 3735411 Mercruiser 17161A1 GM 5.0L/305/ 5.7L</p>	 <p>18-1457 HI-PERFORMANCE TIMING KIT Replaces: OMC 913734, 913725, 986094 Mercruiser 801829, 5.8L/233 Ford</p>	 <p>18-1480 CAMSHAFT Replaces: OMC 380343 Mercruiser 424-2422, 2.5L/120</p>
 <p>18-1481 CAMSHAFT Replaces: Mercruiser 424-3864 3.0L/140 OMC & Volvo 3854262</p>	 <p>18-1482 CAMSHAFT Replaces: Mercruiser 430-3161 250 CID/160, 165 OMC 3891589</p>	 <p>18-1483 CAMSHAFT Replaces: OMC 3883986 Crusader 30162 Mercruiser 431-4734 7.4L/454</p>	 <p>18-1484 CAMSHAFT Replaces: Mercruiser 431-5943 GM 5.7L/350 & 5.0L/305 (Early) OMC 340284</p>
 <p>18-1485 CAMSHAFT (ROLLER) Replaces: Volvo 3853159 OMC 3856119 Mercruiser 431-811658 GM 5.0L/305 & 5.7L/350 (Late)</p>	 <p>18-1486 CAMSHAFT Replaces: OMC 14095859 Mercruiser 431-9433 4.3L/V-6 (Early)</p>	 <p>18-1487 CAMSHAFT (ROLLER) Replaces: OMC & Volvo 3854328 Mercruiser 431-9691 4.3L/V-6 (Late)</p>	 <p>18-1488 CAMSHAFT Replaces: Volvo & OMC 913715, 3852778 Mercruiser 447-5098, 5.0L/888 Ford 302</p>

INTERNAL ENGINE COMPONENTS

A-Parts DEMO Shafts/Timing Kits



MERCURISER LIFTER/CAMSHAFT/TIMING KIT APPLICATION

Model	Serial Number	Lifter	Camshaft	Timing Chain Kit	Model	Serial Number	Lifter	Camshaft	Timing Chain Kit
120	1666601 & Up	18-1402	18-1480	N/A	280 GM	4176250 & Up	18-1402	—	18-1455 ②
140	2508261 - 6229717	18-1402	18-1481	N/A	300 MR/TRS (GM)	6668677 & Up	18-1402	—	18-1455 ②
140/3.0L	6229718 & Up	18-1402	18-1481	N/A	320 GM (EFI)	A543605 & Up	18-1402	—	18-1455 ②
3.0L/3.0LX	C856559 & Up	18-1402	18-1481	N/A	320 GM (EFI)				
140 (6 cyl)	1538930 - 1725960	18-1402	N.L.A.	N/A	Bravo	B157603 & Up	18-1402	—	18-1455 ②
150	166495 - 2048046	18-1402	N.L.A.	N/A	325 GM	2278747 & Up	18-1402	18-1483 ①	18-1450 ④
160	2048022 - 2770031	18-1402	18-1482	N/A	330 GM	4623115 & Up	18-1402	18-1483 ①	18-1450 ④
165	2770032 & Up	18-1402	18-1482	N/A	330 GM/W.B.W.	6083145 & Up	18-1402	18-1483	18-1450 ④
175/4.3L (262 CID)	B527955 & Up	18-1400	18-1487	18-1454	340/7.4L GM (IB)	5889914 & Up	18-1402	18-1483 ①	18-1450 ④
4.3L Generation II	D714107 - F000877	—	—	18-1454	350 GM	3780450 & Up	18-1402	—	18-1450 ④
4.3L Generation II	F000878 & Up	—	—	18-1454	350 GM (Magnum)	A635178 - B525981	18-1402	18-1484	18-1455 ②
185 (229 CID)	6330183 & Up	18-1402	—	N/A	350 GM (Magnum)	B525982 & Up	18-1400	18-1485	18-1455 ②
185 (262 CID)	A331455 & Up	18-1402	18-1486	N/A	350 (Magnum Tourney SKI)	D505450 & Up	18-1400	18-1485	18-1455 ②
190 GM	1564539 - 1730903	18-1402	—	18-1455 ②	370 TRS GM	4179554 & Up	18-1402	—	18-1450 ④
200	2453769 - 2712072	18-1402	N.L.A.	N.L.A.	390 GM	2781129 - 2825059	18-1402	—	18-1450 ④
200 GM	6218462 & Up	18-1402	18-1484	18-1455 ②	400 TRS GM	4179554 & Up	18-1403	—	18-1450 ④
200/5.0L	B525982 & Up	18-1402	18-1485	18-1455 ②	420 GM	A398941 & Up	18-1403	—	18-1450 ④
205 (262 CID)	A331455 & Up	18-1402	18-1486	18-1451	425 GM	A398941 & Up	18-1403	—	18-1450 ④
205/4.3L-LX (262 CID)	B527955 & Up	18-1400	18-1487	18-1454	440 TRS GM	4179554 & Up	18-1402	—	18-1450 ④
4.3LX Generation II	D714370 - F01219	—	—	18-1454	454 GM (Magnum)	A631894 & Up	18-1402	18-1483	18-1450 ④
4.3LX Generation II	F001220 & Up	—	—	18-1454	454 MAG.				
215 Ford	2781153 & Up	18-1401	18-1488	18-1453	Bravo (GM)	B840126 & Up	—	—	18-1450 ④
225 Ford	3385721 & Up	18-1401	18-1488	18-1453	454 MAG				
225 GM	1536920 & Up	18-1402	—	18-1455 ②	Bravo (Gen V)	D805069 & Up	—	—	18-1450 ④
228 GM	4765100 & Up	18-1402	18-1484	18-1455 ②	454 EFI	F115700 & Up	—	—	18-1450 ④
230 GM (IB)	5907058 & Up	18-1402	18-1484	18-1455 ②	460 TRS GM	4179554 & Up	—	—	18-1450 ④
230/5.0L GM (IB)	B522506 & Up	18-1402	18-1484	18-1455 ②	500	C577254 & Up	18-1403	—	—
230 GM	6218462 & Up	18-1402	18-1484	18-1455 ②	502 MAG				
230/5.0L-LX (GM)	B525982 & Up	18-1402	18-1485	18-1455 ②	Bravo (GM)	C878221 & Up	—	—	18-1450 ④
233 Ford	4173000 - 4902304	18-1401	18-1488	18-1457	502 MAG				
250 GM	2314301 - 2639854	18-1402	—	18-1455 ②	Bravo (Gen V)	D824589 & Up	—	—	18-1450 ④
250 GM	4768000 - 4908849	18-1402	18-1484	18-1455 ②	502 EFI	D840650 & Up	—	—	18-1450 ④
255 Ford	3258728 & Up	18-1401	18-1488	18-1457	575	A677429 & Up	—	—	—
255 GM	4175500 & Up	18-1402	18-1484	18-1455 ②	888 Ford	3108723 & Up	18-1401	18-1488	18-1453
260 GM	4908850 - 6218461	18-1402	18-1484	18-1455 ②	898/198 GM	4762210 & Up	18-1402	18-1484	18-1455 ②
260/5.7L (GM)	B525982 & Up	18-1400	18-1485	18-1455 ②	5.7 GM (SKI)	A338553 & Up	18-1402	18-1484	18-1455 ②
260 GM (IB)	5907058 & Up	18-1402	18-1484	18-1455 ②	5.7L Bravo GM	B525982 & Up	18-1400	18-1485	18-1455 ②
260/5.7L GM (IB)	B522506 & Up	18-1402	18-1484	18-1455 ②	7.4L Bravo GM	B771113 & Up	18-1402	18-1483	18-1450 ④
270 GM	2851074 - 3077735	18-1402	—	18-1455 ②	7.4L Bravo (Gen V)	D603118 & Up	—	18-1483	18-1450 ④
					7.4L W/ HURTH (IB)	C391564 & Up	18-1402	18-1483	18-1450 ④
					7.4L (IB/LHR/GEN V)	D715494 & Up	—	18-1483	18-1450 ④
					8.2L W/ HURTH (IB)	C878221 & Up	—	—	18-1450 ④
					8.2L (IB) (Gen V)	D857200 & Up	—	—	18-1450 ④

- ① For chain drive only
- ② For Hi-Performance timing kit use 18-1452
- ③ For SN 6916779 and above only

- ④ Hi-Performance only
- N.L.A. No longer available
- N.A. Not applicable

LIFTER/CAMSHAFT/TIMING KIT APPLICATION							
Eng. Model	Lifter	Camshaft	Timing Chain Kit	Eng. Model	Lifter	Camshaft	Timing Chain Kit
OMC				VOLVO (Cont.)			
GM				GM			
2.5L/153 CID	18-1402	18-1480	—	5.0L/305 CID	18-1402 ⑤	18-1484 ⑦	18-1455 ②
3.0L/181 CID	18-1402	18-1481	—	5.7L/350 CID	18-1402 ⑤	18-1484 ⑦	18-1455 ②
1-6/250 CID	18-1402	18-1482	—	7.4L/454 CID	18-1403	18-1483	18-1450
4.3L/V-6	18-1402 ⑤	18-1486 ⑥	18-1451	FORD			
5.0L/305 CID	18-1402 ⑤	18-1484 ⑦	18-1455 ②	5.0L/302 CID	18-1401	18-1488	18-1453
5.7L/350 CID	18-1402 ⑤	18-1484 ⑦	18-1455 ②	5.8L/351 CID	18-1401	—	—
7.4L/454 CID	18-1403	18-1483	18-1450	CHRIS CRAFT/CRUSADER/PLEASURECRAFT			
FORD				GM			
5.0L/302 CID	18-1401	18-1488	18-1453	4.3L/V-6	18-1402 ⑤	18-1486 ⑥	18-1451
5.8L/351 CID	18-1401	—	18-1457	5.0L/305 CID	18-1402 ⑤	18-1484 ⑦	18-1455 ②
VOLVO				5.7L/350 CID	18-1402 ⑤	18-1484 ⑦	18-1455 ②
GM				7.4L/454 CID	18-1403	18-1483	18-1450
3.0L/181 CID	18-1402	18-1481	—	② For chain drive only			
4.3L/V-6	18-1402 ⑤	18-1486 ⑥	18-1451	⑤ For roller camshafts use 18-1400			
				⑥ For roller camshafts use 18-1487			
				⑦ For roller camshafts use 18-1485			

ALL PISTONS ARE SUPPLIED COMPLETE WITH PISTON RINGS, WRIST PIN AND CIRCLIPS.



RINGS			
STD	REPLACES MERCURUISER	OMC / VOLVO	CRUSADER
18-3928	39-74381A1	—	—
18-3937	39-17464	14089025	12370
18-3937	—	328506	—
18-3937	—	3853960	—
18-3937	—	914555	—
18-3937	—	3853268	—
18-3940	39-67127	328536	30184
18-3942	39-67132	—	—
18-3944	39-75609	370409	33302
.020			
18-3929	—	—	—
18-3939	39-66217	3854252	—
18-3939	—	914556	—
18-3950	—	N/A	—
18-3946	—	—	—
18-3948	—	N/A	—
.030			
18-3930	39-75423	—	—
18-3938	39-17465	14089026	—
18-3938	—	328516	—
18-3938	—	914557	—
18-3938	—	—	12372
18-3941	39-67128	328541	30185
18-3943	39-67134	—	—
18-3945	39-75981	370419	33322
18-4180	736-2343	—	—
18-4161	733-3819	3853340	—
	733-803850T	—	—

PISTONS			
STD	REPLACES MERCURUISER	OMC / VOLVO	CRUSADER
18-4169	734-4858	—	—
18-4109	778-9441A3	—	—
	759-80661A7	—	—
18-4173	735-6370	14077948	7080330 ①
18-4173	735-9686	3911020	—
18-4173	735-808674	—	—
	735-850097	—	—
18-4181	735-6538	364702	—
18-4168	735-9430	—	—
18-4179	735-9716,T1	—	—
18-4179	—	—	33706 ①
18-4176	749-4058	—	—
18-4171	737-6523	—	30246
18-4162	—	—	—
.020			
18-4183	—	—	—
18-4160	733-3818	3853477	—
18-4184	—	—	—
18-4118	—	—	—
18-4188	—	N/A	—
18-4187	—	N/A	—
18-4185	—	—	—
18-4186	—	—	—
18-4177	749-4060	—	—
18-4189	—	—	—
.030			
18-4166	733-2279	—	—
18-4191	—	—	—
18-4170	734-4860	—	—
18-4134	778-9441A5 759-80661A8	—	—
18-4164	735-6371	14077949	7080350 ①
18-4164	735-9687	3911023	—
	735-85009	—	—
18-4182	735-6617	364704	—
18-4164	435-6371	—	—
18-4164	735-9687	—	—
18-4178	735-9715	—	33708 ①
18-4193	—	—	—
18-4172	737-6615	—	30249
18-4163	737-5537	—	—

① Piston & Pin only

INBOARD

INTERNAL ENGINE COMPONENTS

A-PDF Split DEMO
Pistons/Piston Rings



INT. ENG.

PISTON/RING APPLICATION								
Mercruiser		PISTONS			RINGS			Qty. Per Eng.
Model	Serial Number	Std.	.020	.030	Std.	.020	.030	
120/2.5L	1666601 & Up	18-4180	18-4183	18-4166	18-3942	18-3946	18-3943	4
140	2508261-3332137	18-4161	18-4160	18-4191	18-3937	18-3939	18-3938	4
140	3332138 - 5157668	18-4161	18-4160	18-4191	18-3937	18-3939	18-3938	4
140	5157669 - 6229717	18-4161	18-4160	18-4191	18-3937	18-3939	18-3938	4
140/3.0L	6229718 - C856558	18-4161	18-4160	18-4191	18-3937	18-3939	18-3938	4
3.0L/3.0LX	C856559 & Up	-	-	-	18-3937	18-3939	18-3938	6
150	1666495 - 2048046	18-4180	18-4183	18-4166	18-3942	18-3946	18-3943	6
160 (6cyl.)	2048022 - 2770031	N.L.A.	-	N.L.A.	18-3942	18-3946	18-3943	6
165 (6cyl.)	2770032 - & Up	18-4169 ^①	18-4184	18-4170 ^①	18-3942	18-3946	18-3943	6
165/3.7L	6916779 - & Up	18-4109	18-4118	18-4134	18-3928	18-3929	18-3930	4
170 (4cyl.)	6916779 - & Up	18-4109	18-4118	18-4134	18-3928	18-3929	18-3930	6
175/4.3L (262 CID)	B527955 - & Up	18-4173	18-4188	18-4164	18-3937	18-3939	18-3938	6
180/3.7LX (4cyl.)	6916779 - & Up	18-4109	18-4118	18-4134	18-3928	18-3929	18-3930	4
4.3L Generation II	D714107 - & Up	18-4173	18-4188	18-4164	18-3937	18-3939	18-3938	6
185 (229 CID)	6330183 - & Up	18-4181	18-4187	18-4182	18-3944	18-3948	18-3945	6
185 (262 CID)	A331455 - & Up	18-4168	18-4185	18-4164	18-3937	18-3939	18-3938	6
190 GM	1564539 - 1730903	18-4180	18-4183	18-4166	18-3942	18-3946	18-3943	6
190 (4cyl.)	6916779 - & Up	18-4109	18-4118	18-4134	18-3928	18-3929	18-3930	4
200 GM	6218462 - & Up	18-4181	18-4187	18-4182	18-3944	18-3948	18-3945	8
200/5.0L (GM)	B525982 - & Up	18-4179	18-4186	18-4178	18-3944	18-3948	18-3945	8
205 (262 CID)	A331455 - & Up	18-4168	18-4185	18-4164	18-3937	18-3939	18-3938	6
205/4.3LX (262 CID)	B527955 - & Up	18-4173	18-4188	18-4164	18-3937	18-3939	18-3938	6
4.3LX Generation II	D714370 - & Up	18-4173	18-4188	18-4164	18-3937	18-3939	18-3938	6
215 Ford	2781153 - & Up	18-4176	18-4177	18-4193	18-3937	18-3939	18-3938	8
225 Ford	3385721 - & Up	18-4176	18-4177	18-4193	18-3937	18-3939	18-3938	8
225 GM	1536920 - & Up	-	-	N.L.A.	18-3937	18-3939	18-3938	8
228 GM	4765100 - & Up	18-4181	18-4187	18-4182	18-3944	18-3948	18-3945	8
230 GM	6218462 - & Up	18-4181	18-4187	18-4182	18-3944	18-3948	18-3945	8
230 GM (IB)	5907058 - & Up	18-4181	18-4187	18-4182	18-3944	18-3948	18-3945	8
230/5.0L GM (IB)	B522506 - & Up	18-4179	18-4156	18-4178	18-3944	18-3948	18-3945	8
230/5.0-LX (GM)	B525982 - & Up	18-4179	18-4186	18-4178	18-3944	18-3948	18-3945	8
250 GM	2314301 - 2639854	-	N.L.A.	N.L.A.	18-3937	18-3939	18-3938	8
250 GM	4768000 - 4908849	18-4173	18-4188	18-4164	18-3937	18-3939	18-3938	8
255 GM	4175500 - 4498700	18-4173	18-4188	18-4164	18-3937	18-3939	18-3938	8
260 GM	4908850 - 6218461	18-4173	18-4188	18-4164	18-3937	18-3939	18-3938	8
260/5.7L (GM)	B525982 - & Up	18-4173	18-4188	18-4164	18-3937	18-3939	18-3938	8
260-GM (IB)	5907058 - & Up	18-4173	18-4188	18-4164	18-3937	18-3939	18-3938	8
270 GM	2851074 - 3077735	N.L.A.	N.L.A.	N.L.A.	18-3937	18-3939	18-3938	8
300 MR/TRS (GM)	6668677 - & Up	-	-	-	18-3937	18-3939	18-3938	8
320 GM (EFI)	A543605 - & Up	-	-	-	18-3937	18-3939	18-3938	8
320 GM (EFI) Bravo	B157603 - & Up	-	-	-	18-3937	18-3939	18-3938	8
325 GM	2278747 - & Up	N.L.A.	-	N.L.A.	18-3940	18-3950	18-3941	8
330 GM	4623115 - & Up	18-4171	18-4189	18-4172	18-3940	18-3950	18-3941	8
330 GM/W.B.W.	6083145 - & Up	18-4171	18-4189	18-4172	18-3940	18-3950	18-3941	8
340/7.4L-GM (IB)	5889914 - & Up	18-4171	18-4189	18-4172	18-3940	18-3950	18-3941	8
350 GM	3780450 - & Up	18-4162	-	18-4163	18-3940	18-3950	18-3941	8
350 GM Magnum	A635178 - & Up	18-4173	18-4188	18-4164	18-3937	18-3939	18-3938	8
350 GM Magnum	B525982 - & Up	18-4173	18-4188	18-4164	18-3937	18-3939	18-3938	8
350 Magnum Tourney SKI	D505450 - & Up	18-4173	18-4188	18-4164	18-3937	18-3939	18-3938	8
370 TRS-GM	4179554 - & Up	18-4162	-	18-4163	18-3940	18-3950	18-3941	8
390-GM	2781129 - 2825059	N.L.A.	N.L.A.	N.L.A.	18-3940	18-3950	18-3941	8
400 TRS-GM	4179554 - & Up	18-4162	-	18-4163	18-3940	18-3950	18-3941	8
420-GM	A398941 - & Up	18-4162	-	18-4163	18-3940	18-3950	18-3941	8
425-GM	A398941 - & Up	18-4162	-	18-4163	18-3940	18-3950	18-3941	8
440 TRS-GM	4179554 - & Up	18-4162	-	18-4163	18-3940	18-3950	18-3941	8
454 GM Magnum	A631894 - & Up	18-4171	18-4189	18-4172	18-3940	18-3950	18-3941	8

① S/N 3212085 and above only
N.L.A. No longer available from O.E. source

Mercruiser		PISTONS			RINGS			Qty. Per Eng.
Model	Serial Number	Std.	.020	.030	Std.	.020	.030	
454 Magnum Bravo (GM)	B840126 - & Up	18-4162	-	18-4163	18-3940	18-3950	18-3941	8
470	4208730 - & Up	18-4109	18-4118	18-4134	18-3928	18-3929	18-3930	4
485	5685394 - & Up	18-4109	18-4118	18-4134	18-3928	18-3929	18-3930	4
488	6170297 - & Up	18-4109	18-4118	18-4134	18-3928	18-3929	18-3930	4
888	3108723 - & Up	18-4176	18-4177	18-4193	18-3937	18-3939	18-3938	8
898/198-GM	4762210 - & Up	18-4181	18-4187	18-4182	18-3944	18-3948	18-3945	8
5.7 G.M (SKI)	A338553 - & Up	18-4173	18-4188	18-4164	18-3937	18-3939	18-3938	8
5.7L Bravo - GM	B525982 - & Up	18-4173	18-4188	18-4164	18-3937	18-3939	18-3938	8
7.4L Bravo GM	B771113 - & Up	18-4171	18-4189	18-4172	18-3940	18-3950	18-3941	8
7.4L W/HURTH (IB)	C391564 - & Up	18-4171	18-4189	18-4172	18-3940	18-3950	18-3941	8

Model	PISTONS			RINGS			Qty. Per Eng.
	Std.	.020	.030	Std.	.020	.030	
OMC							
GM							
2.5L/153 CID	18-4180	18-4183	18-4166	18-3942	18-3946	18-3943	4
3.0L/181 CID	18-4161	18-4160	18-4191	18-3937	18-3939	18-3938	4
I-6/250 CID	18-4169	18-4184	18-4170	18-3942	18-3946	18-3943	6
4.3L/V-6	18-4173	18-4188	18-4164	18-3937	18-3939	18-3938	6
5.0L/305 CID	18-4179	18-4186	18-4178	18-3944	18-3948	18-3945	8
5.7L/350 CID	18-4173	18-4188	18-4164	18-3937	18-3939	18-3938	8
7.4L/454 CID	18-4171 ②	18-4189	18-4172 ③	18-3940	18-3950	18-3941	8
FORD							
5.0L/302 CID	18-4176	18-4177	18-4193	18-3937	18-3939	18-3938	8
VOLVO							
GM							
2.5L/153 CID	18-4180	18-4183	18-4166	18-3942	18-3946	18-3943	4
3.0L/181 CID	18-4161	18-4160	18-4191	18-3937	18-3939	18-3938	4
4.3L/V-6	18-4173	18-4188	18-4164	18-3937	18-3939	18-3938	6
5.0L/305 CID	18-4179	18-4186	18-4178	18-3944	18-3948	18-3945	8
5.7L/350 CID	18-4173	18-4188	18-4164	18-3937	18-3939	18-3938	8
7.4L/454 CID	18-4171 ②	18-4189	18-4172 ③	18-3940	18-3950	18-3941	8
FORD							
5.0L/302 CID	18-4176	18-4177	18-4193	18-3937	18-3939	18-3938	8
CHRIS CRAFT/CRUSADER/PLEASURECRAFT							
GM							
4.3L/V6	18-4173	18-4188	18-4164	18-3937	18-3939	18-3938	6
5.0L/305 CID	18-4179	18-4186	18-4178	18-3944	18-3948	18-3945	8
5.7L/350 CID	18-4173	18-4188	18-4164	18-3937	18-3939	18-3938	8
7.4L/454 CID	18-4171 ②	18-4189	18-4172 ③	18-3940	18-3950	18-3941	8

② For forged pistons use 18-4162 (use 18-3940 rings)
 ③ For forged pistons use 18-4163 (use 18-3941 rings)



INT. ENG.

INTERNAL ENGINE COMPONENTS

A-PDF Split DEMO



INT. ENG.

 <p>ROD BEARINGS</p>			 <p>MAIN BEARINGS</p>						 <p>CAM BEARINGS</p>				
Part #	Size	Replaces Mercruiser:	Part #	Per Eng.	Size	Replaces Mercruiser:	Part #	Per Eng.	Size	Replaces Mercruiser:	Part #	Per Eng.	Replaces Mercruiser:
18-1133	.020	68704A3	18-1131	4	.010	74313A4	18-1314	1	.020	23-818477	18-1303	1	23-801849
18-1135	.002	68704A2	18-1132	4	.020	74313A3	18-1315	1	Std.	23-818473	18-1304	1	23-56124
18-1136	.010	68704A4	18-1137	1	.020	15103-A3	18-1316	1	.010	23-818471	18-1305	1	23-85684
18-1148	Std.	68704A1	18-1138	1	.010	15103-A4	18-1317	1	Std.	23-818469	18-1306	1	23-801797
18-1308	Std.	23-85701	18-1147	4	Std.	74313A1	18-1318	1	.020	23-818472	18-1307	1	23-801851
18-1309	.010	23-85704	18-1149	1	Std.	15103A1	18-1319	1	.020	23-801804	18-1313	1	23-85674
18-1325	.010	23-85732	18-1300	1	Std.	23-818465	18-1320	1	.010	23-801803	18-1331	1	23-85720
18-1326	.020	23-85733	18-1301	1	.010	23-818467	18-1321	1	Std.	23-801801	18-1339	1	23-43293
18-1327	Std.	23-11992	18-1302	1	.020	23-818468	18-1322	1	.020	23-801819	18-1340	5	23-67484
18-1328	.020	23-85681	18-1310	1	.020	23-801796	18-1323	1	Std.	23-801816			
18-1329	Std.	23-85677	18-1311	1	Std.	23-801793	18-1324	1	.010	23-801818			
18-1330	.010	23-85680	18-1312	1	.010	23-801795	18-1335	1	.010	23-818476			
18-1332	.020	23-85729											
18-1333	.010	23-85691											
18-1334	Std.	23-85726											
18-1336	Std.	23-56116											
18-1337	.010	23-811858											
18-1338	.020	23-811859											
18-1341	.020	23-85705											

① Thrust bearing ② Complete engine set

Mercruiser Bearing Application		ROD BEARING			MAIN BEARING			CAM BEARING
Model	Serial Number	Std.	.010	.020	Std.	.010	.020	
120/2.5L	1666601 & Up	18-1329	18-1330	18-1328	18-1317	18-1316	18-1318	18-1331 ①
140	2508261 - 3462607	18-1308	18-1309	18-1341	18-1317	18-1316	18-1318	18-1331
140	3462608 - 5157668	18-1308	18-1309	18-1341	18-1317	18-1316	18-1318	18-1339
140	5157669 - 6229717	18-1308	18-1309	18-1341	18-1317	18-1316	18-1318	18-1339
140/3.0L	6229718 & Up	18-1308	18-1309	18-1341	18-1317	18-1316	18-1318	18-1339
3.0/3.0LX	C856559 & Up	18-1308	18-1309	18-1341	18-1317	18-1316	18-1318	18-1339
140 (6cyl)	1538930 - 1725960	18-1329	18-1330	18-1328	N.L.A.	N.L.A.	N.L.A.	N.L.A.
150	1666495 - 2048046	18-1329	18-1330	18-1328	N.L.A.	N.L.A.	N.L.A.	N.L.A.
160	2048022 - 2770031	18-1329	18-1330	18-1328	18-1321	18-1320	18-1319	18-1303
165	2770032 & Up	18-1329	18-1330	18-1328	18-1321	18-1320	18-1319	18-1303 ②
165 (4 cyl.)	6916779 & Up	See specific application chart on page 460						18-1340
170 (4 cyl.)	6916779 & Up	See specific application chart on page 460						18-1340
180/3.7L-LX (4 cyl)	6916779 & Up	See specific application chart on page 460						18-1340
175/4.3L (262 CID)	B527955 & Up	18-1327	18-1337	18-1338	18-1311	18-1312	18-1310	18-1306
4.3L Generation II	D714107 & Up	18-1327	18-1337	18-1338	18-1311	18-1312	18-1310	18-1306
185 (229 CID)	6330183 & Up	-	-	-	18-1300	18-1301	18-1302	18-1313
185 (262 CID)	A331455 & Up	18-1327	18-1337	18-1338	18-1311	18-1312	18-1310	18-1306
190 GM	1564539 - 1730903	18-1329	18-1330	18-1328	-	-	-	18-1313
190 (4 cyl)	6916779 & Up	See specific application chart on page 460						18-1340
200	2453769 - 2712072	18-1308	18-1309	18-1341	18-1317	18-1316	18-1318	18-1331
200 GM	6218462 & Up	18-1308	18-1309	18-1341	18-1300	18-1301	18-1302	18-1313
200/5.0L	B525982 & Up	18-1308	18-1309	18-1341	18-1300	18-1301	18-1302	18-1313
205 (262 CID)	A331455 & Up	18-1327	18-1337	18-1338	18-1311	18-1312	18-1310	18-1306
205/4.3L-LX (262 CID)	B527955 & Up	18-1327	18-1337	18-1338	18-1311	18-1312	18-1310	18-1306
4.3LX Generation II	D714370 & Up	18-1327	18-1337	18-1338	18-1311	18-1312	18-1310	18-1306
215 Ford	2781153 & Up	18-1336	18-1325	18-1326	18-1323	18-1324	18-1322	18-1304
225 Ford	3385721 & Up	18-1329	18-1330	18-1328	18-1323	18-1324	18-1322	18-1304
225 GM	1536920 - 2278646	18-1329	18-1330	18-1328	-	-	-	18-1313
225 GM	2278647 - 2399397	18-1329	18-1330	18-1328	18-1317	18-1316	18-1318	18-1313

① For S/N 4469865 and below only, for S/N 4469866 and above use **18-1339**.
 ② For S/N 2963668 and above use **18-1307**.









Model	Serial Number	ROD BEARING			MAIN BEARING			CAM BEARING
		Std.	.010	.020	Std.	.010	.020	
225 GM	2399398 & Up	18-1308	18-1309	18-1341	18-1300	18-1301	18-1302	18-1313
228 GM	4765100 & Up	18-1308	18-1309	18-1341	18-1300	18-1301	18-1302	18-1313
230 GM (IB)	5907058 & Up	18-1308	18-1309	18-1341	18-1300	18-1301	18-1302	18-1313
230/5.0L GM (IB)	B522506 & Up	18-1308	18-1309	18-1341	18-1300	18-1301	18-1302	18-1313
230 GM	6218462 & Up	18-1308	18-1309	18-1341	18-1300	18-1301	18-1302	18-1313
230/5.0L-LX (GM)	B525982 & Up	18-1308	18-1309	18-1341	18-1300	18-1301	18-1302	18-1313
233 Ford	4173000 - 4902304	-	-	-	-	-	N.L.A.	18-1304
250 GM	2314301 - 2639854	18-1308	18-1309	18-1341	18-1300	18-1301	18-1302	18-1313
250 GM	4768000 - 4908849	18-1308	18-1309	18-1341	18-1300	18-1301	18-1302	18-1313
255 Ford	3258728 & Up	-	-	-	-	-	N.L.A.	18-1304
255 GM	4175500 & Up	18-1308	18-1309	18-1341	18-1300	18-1301	18-1302	18-1313
260 GM	4908850 - 6218461	18-1308	18-1309	18-1341	18-1300	18-1301	18-1302	18-1313
260/5.7 (GM)	B525982 & Up	18-1308	18-1309	18-1341	18-1300	18-1301	18-1302	18-1313
260 GM ((IB))	5907058 & Up	18-1308	18-1309	18-1341	18-1300	18-1301	18-1302	18-1313
260/5.7L GM (IB)	B522506 & Up	18-1308	18-1309	18-1341	18-1300	18-1301	18-1302	18-1313
270 GM	2851074 - 3077735	18-1308	18-1309	18-1341	18-1300	18-1301	18-1302	18-1313
280 GM	4176250 & Up	18-1308	18-1309	18-1341	18-1300	18-1301	18-1302	18-1313
300 MR/TRS (GM)	6668677 & Up	18-1308	18-1309	18-1341	18-1300	18-1301	18-1302	18-1313
320 GM (EFI)	A543605 & Up	18-1308	18-1309	18-1341	18-1300	18-1301	18-1302	18-1313
320 GM (EFI) Bravo	B157603 & Up	18-1308	18-1309	18-1341	18-1300	18-1301	18-1302	18-1313
325 GM	2278747 & Up	18-1334	18-1333	18-1332	18-1315	18-1335	18-1314	18-1305
330 GM	4623115 & Up	18-1334	18-1333	18-1332	18-1315	18-1335	18-1314	18-1305
330 GM/W.B.W.	6083045 & Up	18-1334	18-1333	18-1332	18-1315	18-1335	18-1314	18-1305
340/7.4LGM(IB)	5889914 & Up	18-1334	18-1333	18-1332	18-1315	18-1335	18-1314	18-1305
350 GM	3780450 & Up	18-1334	18-1333	18-1332	18-1315	18-1335	18-1314	18-1305
350 GM Magnum	A635178 & Up	18-1308	18-1309	18-1341	18-1300	18-1301	18-1302	18-1313
350 (Magnum Tourney SKI)	D505450 & Up	18-1308	18-1309	18-1341	18-1300	18-1301	18-1302	18-1313
370 TRS-GM	6721528 & Up	18-1334	18-1333	18-1332	18-1315	18-1335	18-1314	-
390 GM	2781129 - 2825059	18-1334	18-1333	18-1332	18-1315	18-1335	18-1314	18-1305
420 GM	A398941 & Up	18-1334	18-1333	18-1332	18-1315	18-1335	18-1314	-
425 GM	A398941 & Up	18-1334	18-1333	18-1332	18-1315	18-1335	18-1314	-
454 GM Magnum	A631894 & Up	18-1334	18-1333	18-1332	18-1315	18-1335	18-1314	18-1305
454 Magnum Bravo (GM)	B840126 & Up	18-1334	18-1333	18-1332	18-1315	18-1335	18-1314	-
454 Magnum Bravo Generation V)	D805069 & Up	18-1334	18-1333	18-1332	18-1315	18-1335	18-1314	18-1305
454 EFI	F115700 & Up	18-1334	18-1333	18-1332	18-1315	18-1335	18-1314	18-1305
470	4208730 & Up	See specific application chart on page 460						18-1340
485	5685394 & Up	See specific application chart on page 460						18-1340
488	6170297 & Up	See specific application chart on page 460						18-1340
502 Magnum Bravo (GM)	C878221 & Up	18-1334	18-1333	18-1332	18-1315	18-1335	18-1314	18-1305
502 Magnum Bravo Generation V)	D824589 & Up	18-1334	18-1333	18-1332	18-1315	18-1335	18-1314	18-1305
502 EFI	D840650 & Up	18-1334	18-1333	18-1332	18-1315	18-1335	18-1314	18-1305
888 Ford	3108723 & Up	18-1336	18-1325	18-1326	18-1323	18-1324	18-1322	18-1304
898/198 GM	4762210 & Up	18-1308	18-1309	18-1341	18-1300	18-1301	18-1302	18-1313
5.7 GM (SKI)	A338553 & Up	18-1308	18-1309	18-1341	18-1300	18-1301	18-1302	18-1313
5.7 Bravo (GM)	B525982 & Up	18-1308	18-1309	18-1341	18-1300	18-1301	18-1302	18-1313
7.4L Bravo GM	B771113 & Up	18-1334	18-1333	18-1332	18-1315	18-1335	18-1314	18-1305
7.4L Bravo (GEN V)	D603118 & Up	18-1334	18-1333	18-1332	18-1315	18-1335	18-1314	18-1305
7.4L W/HURTH (IB)	C391564 & Up	18-1334	18-1333	18-1332	18-1315	18-1335	18-1314	18-1305
7.4L (IB/LHR/GENV)	D715494 & Up	18-1334	18-1333	18-1332	18-1315	18-1335	18-1314	18-1305
8.2L W/HURTH (IB)	C878221 & Up	18-1334	18-1333	18-1332	18-1315	18-1335	18-1314	18-1305
8.2L (IB)(Generation V)	D857200 & Up	18-1334	18-1333	18-1332	18-1315	18-1335	18-1314	18-1305

BEARING APPLICATION CONTINUED ON NEXT PAGE

INT. ENG.

MERCURISER 3.7L BEARING APPLICATION											
Model	Serial Number	ROD BEARINGS				MAIN BEARINGS			MAIN (THRUST BEARINGS)		
		Std.	.002	.010	.020	Std.	.010	.020	Std.	.010	.020
165\3.7 (4cyl)	6916779 & Up	18-1148	18-1135	18-1136	18-1133	18-1147	18-1131	18-1132	18-1149	18-1138	18-1137
170 (4cyl)	6916779 & Up	18-1148	18-1135	18-1136	18-1133	18-1147	18-1131	18-1132	18-1149	18-1138	18-1137
180\3.7L (4cyl)	6916779 & Up	18-1148	18-1135	18-1136	18-1133	18-1147	18-1131	18-1132	18-1149	18-1138	18-1137
190 (4cyl)	6916779 & Up	18-1148	18-1135	18-1136	18-1133	18-1147	18-1131	18-1132	18-1149	18-1138	18-1137
470	4208730 & Up	18-1148	18-1135	18-1136	18-1133	18-1147	18-1131	18-1132	18-1149	18-1138	18-1137
485	5685394 & Up	18-1148	18-1135	18-1136	18-1133	18-1147	18-1131	18-1132	18-1149	18-1138	18-1137
488	6170297 & Up	18-1148	18-1135	18-1136	18-1133	18-1147	18-1131	18-1132	18-1149	18-1138	18-1137
		ROD BEARING			MAIN BEARING			CAM Bearing			
Model		Std.	.010	.020	Std.	.010	.020				
OMC											
GM											
2.5L/153 CID		18-1329	18-1330	18-1328	18-1317	18-1316	18-1318	18-1339 ③			
3.0L/181 CID		18-1308	18-1309	18-1341	18-1317	18-1316	18-1318	18-1339 ③			
I-6/230 CID		18-1329	18-1330	18-1328	18-1321	18-1320	18-1319	18-1303			
I-6/250 CID		18-1308	18-1309	18-1341	18-1321	18-1320	18-1319	18-1307 ④			
4.3L/V-6		18-1327	18-1337	18-1338	18-1311	18-1312	18-1310	18-1306			
5.0L/305 CID		18-1308	18-1309	18-1341	18-1300	18-1301	18-1302	18-1313			
5.7L/350 CID		18-1308	18-1309	18-1341	18-1300	18-1301	18-1302	18-1313			
7.4L/454 CID		18-1334	18-1333	18-1332	18-1315	18-1335	18-1314	18-1305			
FORD											
5.0L/302 CID		18-1336	18-1325	18-1326	18-1323	18-1324	18-1322	18-1304			
5.8L/351 CID		-	-	-	-	-	-	18-1304			
VOLVO											
GM											
3.0L/181 CID		18-1308	18-1309	18-1341	18-1317	18-1316	18-1318	18-1339			
4.3L/V-6		18-1327	18-1337	18-1338	18-1311	18-1312	18-1310	18-1306			
5.0L/305 CID		18-1308	18-1309	18-1341	18-1300	18-1301	18-1302	18-1313			
5.7L/350 CID		18-1308	18-1309	18-1341	18-1300	18-1301	18-1302	18-1313			
7.4L/454 CID		18-1334	18-1333	18-1332	18-1315	18-1335	18-1314	18-1305			
FORD											
5.0L/302 CID		18-1336	18-1325	18-1326	18-1323	18-1324	18-1322	18-1304			
5.8L/351 CID		-	-	-	-	-	-	18-1304			
CHRIS CRAFT/CRUSADER/PLEASURECRAFT											
GM											
4.3L/V-6		18-1327	18-1337	18-1338	18-1311	18-1312	18-1310	18-1306			
5.0L/305 CID		18-1308	18-1309	18-1341	18-1300	18-1301	18-1302	18-1313			
5.7L/350 CID		18-1308	18-1309	18-1341	18-1300	18-1301	18-1302	18-1313			
7.4L/454 CID		18-1334	18-1333	18-1332	18-1315	18-1335	18-1314	18-1305			

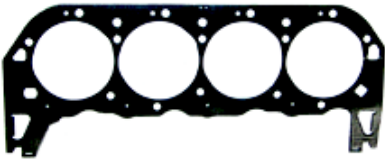
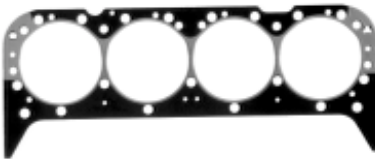
③ Early engines with housing bore diameters (#1 & #2) 1.99/2.001 (#3) 2.009/2.011 use 18-1331
 ④ Early engines with housing bore diameters (#1 & #4) 2.009/2.011 (#2 & #3) 1.99/2.001 use 18-1303

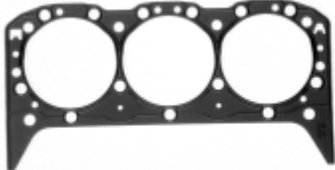
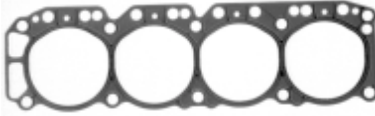
<p>PKG. OF 4</p>  <p>18-0518 AP# 792 VALVE STEM SEAL Replaces: Mercruiser 26-34217 OMC & Volvo 3854956 Crusader 7230530 For: most inline 4 and 6 cyl. GM (Early) and 305-350 CID GM</p>	 <p>18-4023 AP# 542 VALVE STEM SEAL Replaces: Mercruiser 26-75413 For: 165, 170, 180, 190 4 cyl. (224 CID) SN 6916779 & later</p>	 <p>18-4022 AP# 534 VALVE STEM SEAL Replaces: Mercruiser 26-75988 For: 330 (SN 4623115 & later), 340 (IB) (SN 5889914 & later), 454 Mag (SN A631894 & later)</p>	 <p>18-4024 INTAKE VALVE SEAL Replaces: Mercruiser 26-97664 Volvo & OMC 3853226 Crusader 7231090 For: Chevy 4.3L/5.0L/5.7L</p>
<p>PKG. OF 8</p>  <p>BRONZE FREEZE PLUGS 18-5961 18-5962 AP #13415 AP # 13416 1 5/8" 1 3/4" Mercruiser 19-34270 Mercruiser 19-37478</p>	 <p>18-2946 AP# 1827 HEAD GASKET Replaces: Mercruiser 27-52364 OMC & Volvo 3853336, 908611 ChrisCraft 16.50-00204 For: GM 181 (3.0L) CID Eng.</p>	 <p>18-3873 HEAD GASKET Replaces: Mercruiser 27-811207 OMC 915927 PCMRM0226 Crusader 31004 For: 502 CID</p>	
 <p>18-3874 HEAD GASKET Replaces: Mercruiser 27-811546 OMC 3853511 Crusader 31137 For: (8.2L) 502 CID / 7.4L</p>	 <p>18-3876 HEAD GASKET Replaces: Mercruiser 27-75611 OMC & Volvo 3853380, 914971 Volvo 841207-4, 856474-2 Crusader 7057500 ChrisCraft 16.50-00250 For: GM 305 (5.0L)/350 (5.7L) CID Eng.</p>	 <p>18-3877 AP# 533 HEAD GASKET Replaces: Mercruiser 27-13687 OMC 914849 Crusader 30266 ChrisCraft 16.50-00259 GM 6258714 For: GM 454 (7.4L) CID Eng.</p>	
 <p>18-3878 AP# 551 HEAD GASKET Replaces: Mercruiser 27-13709T OMC 912766 For: Mercruiser 224 (3.7L) CID Eng., Model 470</p>	 <p>18-3879 AP# 1469 HEAD GASKET Replaces: Mercruiser 27-11986, 27-816460 OMC & Volvo 3854299, 912227, 914930 For: GM 262 (4.3L) CID Eng.</p>	 <p>18-3880 HEAD GASKET Replaces: Mercruiser 27-34273, Mercruiser 27-810841, 27-52364 OMC 311210 For: GM 153 (2.5L), (3.0L) CID Eng.</p>	

INT. ENG.

INTERNAL ENGINE COMPONENTS

A-PDF Split DEMO Head Gaskets/Crank Shaft/Timing Cover Seals



18-3881
ap# 522
HEAD GASKET
Replaces: Mercruiser 27-47453
Mercruiser 27-72622
OMC 908237
For: GM 250 (4.1L) CID (6 cyl) Eng.

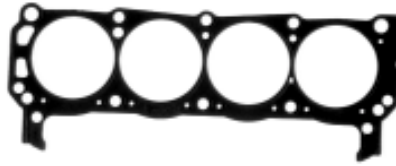

AP# 540
HEAD GASKET
Replaces: Mercruiser 27-75647
OMC & Volvo 3853732
For: Ford 302 (5.0L) 351 (5.8L) CID Eng.



18-3887
AP# 2524
HEAD GASKET
Replaces: Mercruiser 27-850470
Crusader 31136
OMC 915325
For: (7.4L) 454 CID GEN V



One Piece Rear Main Crankshaft Seals

18-1234
AP# 2497
Replaces:
Mercruiser
26-811554
Crusader 7080030
OMC 3853528

18-0519
AP# 1806
Replaces:
Mercruiser
26-14240
Crusader 7070400
OMC & Volvo
3852657
4.3L/3.0L/5.0L 5.7L



Two Piece Rear Main Crankshaft Seals

18-1214
Replaces:
Mercruiser
26-75980

18-1215
Replaces:
Mercruiser
26-15123

18-1216
Replaces:
Mercruiser
27-35313

18-0520
AP# 1074
Replaces:
Mercruiser
26-14756
Crusader 30238
OMC 460571

18-0528
AP# 2547
Replaces:
Mercruiser
26-56868
OMC 913745

18-1211
AP# 279
Replaces:
Mercruiser
26-58203, 26-814622
OMC 473424

18-1223
AP# 1075
Replaces:
Mercruiser
26-64796
OMC 913746



Timing Cover Seals

18-1213
AP# 1055
Replaces:
Mercruiser
26-79223,
26-97335, 26-59341
Crusader 7080310
OMC & Volvo 3853341

18-1230
AP# 2546
Replaces:
Mercruiser
26-56866
OMC & Volvo
3853827

18-1233
AP# 2496
Replaces: Mercruiser 26-821947-1
OMC 3860095
Crusader 7080130

MERCUISER SEAL APPLICATION

Model	Serial No.	Sierra Rear Main Crankshaft Seal	Sierra Timing Cover Seal
120/2.5L	1666601 & UP	—	18-1213
120/2.5L	2786857 & UP	18-1211	18-1213
140/3.0L & LX	2508261 & UP	—	18-1213
140/3.0L & LX	6229718 & UP	18-1211	18-1213
150/160/165/200 (I/L-6)	1666495 & UP	—	18-1213
150/160/165/200 (I/L-6)	2770032 & UP	18-1211	18-1213
175/185/205/262/4.3L (V-6)	6330183 & UP	18-1211	18-1213
200/228/225/230/250/255/260/270 280/300/320/5.0L/5.7L/898(V-8)	2453769 & UP	18-1211 ^①	18-1213
233, 233 MIE / 255, 255 MIE, 351W	3258728 & UP	18-1223	18-1230
215	2781153 & UP	18-0528	18-1230
224I/L4	ALL	18-0864	18-0578
225 FORD	3885721 & UP	18-0528	18-1230
5.0L/5.7L, 4.3L, 3.0L Std. Rotation	"All" one piece seal	18-0519	18-1213
340 (7.4L)	4623115 & UP	18-0520	18-1233
370 TRS	5889914 & UP	18-0520	18-1233
400 TRS	4179554 & UP	18-0520	18-1233
420	A398941 & UP	18-0520	18-1233
440 TRS	4179554 & UP	18-0520	18-1233
454 MAGNUM	A631894 & UP	18-0520	18-1233
460 TRS	4179554 & UP	18-0520	18-1233
7.4L/8.2L/454/502 Std. Rotation	"All" one piece seal	18-1234	18-1233
7.4 BRAVO	B771113 & UP	18-0520	18-1233
888 (188)	3108723 & UP	18-0528	18-1230

^① Lrg. Journal Crankshaft GM Engines

INT. ENG.

OMC SEAL APPLICATION			
Engine Model	2 Piece Rear Main Crankshaft Seal Conv. Rotation (LH)	2 Piece Rear Main Crankshaft Seal Reverse Rotation (RH)	Timing Cover Seal
GM			
2.5L/153 CID	18-1211 ②	18-1216	18-1213
3.0L/181 CID	18-1211 ②	18-1216	18-1213
I-6/230CID	18-1211 ②	18-1216	18-1213
I-6/250CID	18-1211 ②	18-1216	18-1213
4.3L/V-6	18-1211 ②	18-1216	18-1213
5.0L/305 CID	18-1211 ① ②	18-1216	18-1213
5.7L/350 CID	18-1211 ① ②	18-1216	18-1213
7.4L/454 CID	18-0520 ③	18-1214	18-1233
FORD			
5.0L/302 CID	18-0528	-	18-1230
5.8L/351 CID	18-1223	-	18-1230
VOLVO SEAL APPLICATION			
Engine Model	2 Piece Rear Main Crankshaft Seal Conv. Rotation (LH)	2 Piece Rear Main Crankshaft Seal Reverse Rotation (RH)	Timing Cover Seal
GM			
3.0L/181 CID	18-1211 ②	18-1216	18-1213
4.3L/V-6	18-1211 ②	18-1216	18-1213
5.0L/305 CID	18-1211 ① ②	18-1216	18-1213
5.7L/350 CID	18-1211 ① ②	18-1216	18-1213
7.4L/454 CID	18-0520 ③	18-1214	18-1233
FORD			
5.0L/302 CID	18-0528	-	18-1230
5.8L/351 CID	18-1223	-	18-1230
CHRIS CRAFT/CRUSADER/PLEASURECRAFT SEAL APPLICATION			
Engine Model	2 Piece Rear Main Crankshaft Seal Conv. Rotation (LH)	2 Piece Rear Main Crankshaft Seal Reverse Rotation (RH)	Timing Cover Seal
GM			
4.3L/V-6	18-1211 ②	18-1216	18-1213
5.0L/305 CID	18-1211 ① ②	18-1216	18-1213
5.7L/350 CID	18-1211 ① ②	18-1216	18-1213
7.4L/454 CID	18-0520 ③	18-1214	18-1233
FORD			
5.0L/302 CID	18-0528	-	18-1230
5.8L/351 CID	18-1223	-	18-1230
① Lrg. Journal Crankshaft GM Engines ② For one piece seal (RH) models use 18-0519 (LH) models use 18-1215 ③ For one piece seal (RH) models use 18-1234			

MODULAR GASKET KITS

Easy to use Modular Gasket Kits for Ford & Chevrolet Marine Engines

- For most popular marine versions of: Chevrolet In-line 4 & 6 cylinder V6 & V8 Engines and Ford 5.0 L & 5.8L V8 Engines
- Minimizes inventory investment to cover most major engine applications
- Maximizes inventory utilizations via mix and match system
- Utilizes generic type gasket kits common among all engine brands., (i.e. a 350CID (5.7L) Crusader & Mercruiser would use the same short block & valve grind gasket sets, but would use different exhaust manifold gasket kits)

CHEVY 4 cyl. 153/2.5L 1965-88 ③

CHEVY 4 cyl. 181/3.0L 1973-84 ③

CHEVY 4 cyl. 181/3.0L 1985-89 (4 cyl. 181/3.0L HO 1990-98) ③

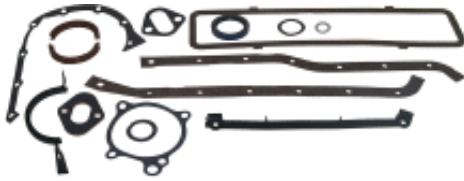

SHORT BLOCK KIT 18-1271 ③
AP# 2567 ①
— CONTAINS —

Description	Sierra #	AP #
Oil Pan Gasket	18-0466	749
Forward Crankshaft Seals	18-1213	1055
Rear Crankshaft Seals	18-1211	279
Push Rod Cover	18-0328	347
Water Pump Gasket	18-0327	346
Fuel Pump Mounting Gasket	18-0889	348
Fuel Pump Mounting Gasket	NSS	NSS
Cam Gear Cover Gasket	18-0887	355
Distributor Mounting Gasket	18-0948	748
Distributor Mounting Gasket	18-0874	373



VALVE GRIND KIT 18-1274
AP# 2581 ②
— CONTAINS —

Description	Sierra #	AP #
Head Gasket	18-2946	—
Mercarb Mounting Gasket	18-0994	333
Carb. Mounting Gasket	18-0356	344
Thermostat Housing Gasket	18-0164	345
Valve Cover Gasket	18-0347	357
Valve Stem Seals (8)	18-0518	792

4 cyl. 3.7L Mercruiser 470

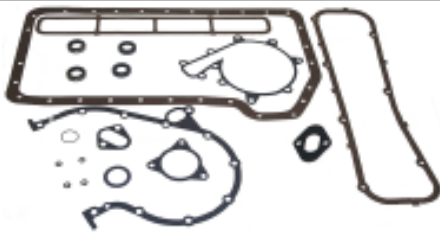

SHORT BLOCK KIT 18-1276
AP# 3646
— CONTAINS —

Description	Sierra #	AP #
Oil Seal	18-2014	171
Mounting Gasket	NSS	NSS
Distributor Mounting Gasket	18-0874	373
Fuel Pump Mounting Gasket	18-0889	348
O-Ring	NSS	NSS
Water Pump Seal	18-0172	147
O-Ring	18-7145	1675
Oil Pan Gasket	18-4366	1528
Water Pump Timer Cover Gasket	NSS	NSS

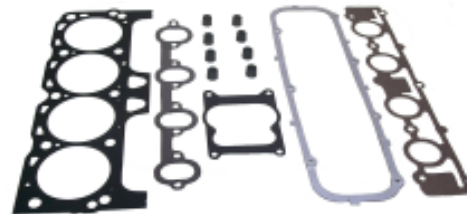

VALVE GRIND KIT 18-1277
AP# 3647
— CONTAINS —

Description	Sierra #	AP #
Intake Gasket	18-0158	334
Quadrajt Gasket	18-2848	359
Valve Grind Cover Gasket	NSS	NSS
Head Gasket	18-3878	551
Exhaust Manifold Mounting Gasket	18-0992	1494
Valve Seal	NSS	NSS

① Except models with cast push rod cover

② Does not include intake/exhaust manifold gaskets

③ For models with 1 piece rear main seal use 18-1206/AP# 2582

NSS Not Sold Separately

MODULAR GASKET KITS

CHEVY L-6 250/4.1L



SHORT BLOCK KIT 18-1255
AP# 2551
(24 Bolt Pan Only)
— CONTAINS —

Description	Sierra #	AP #
Oil Pan Gasket	18-0340	521
Forward Crankshaft Seals	18-1213	1055
Rear Crankshaft Seals	18-1211	279
Push Rod Cover	18-0329	1124
Water Pump Gasket	18-0327	346
Fuel Pump Mounting Gasket	18-0889	348
Timing Gear Cover Gasket	18-0887	355
Distributor Mounting Gasket	18-0874	373

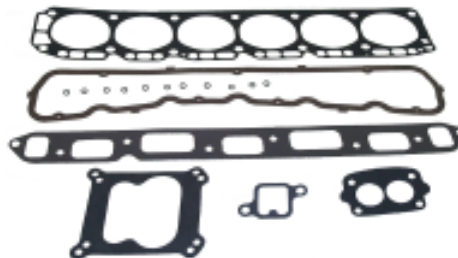

VALVE GRIND KIT 18-1264
AP# 2560
— CONTAINS —

Description	Sierra #	AP #
Head Gasket	18-3881	522
4BBL Carb Mounting Gasket	NSS	NSS
2BBL Carb Mounting Gasket	18-0356	344
Exhaust Manifold Gasket	18-2830	332
T-Stat Hsg. Mounting Gasket	18-0164	345
Valve Cover Gasket	18-0346	1125
Valve Stem Seals (8)	18-0518	792

CHEVY V-6 229/3.8L AND 4.3L



SHORT BLOCK KIT 18-1270
AP# 2566*
— CONTAINS —

Description	Sierra #	AP #
Oil Pan Gasket	18-0405	—
Oil Drain Screw Gasket	18-0905	356
Forward Crankshaft Seals	18-1213	1055
Rear Crankshaft Seal	18-0519	1806
Crankshaft Seal Retainer	18-0322	1474
Water Pump Mounting Gasket	18-0891	352
Fuel Pump Plate Gasket	NSS	NSS
Fuel Pump Mounting Gasket	18-0889	348
Timing Chain Cover Gasket	18-0976	1129
Timing Chain Cover Gasket	NSS	NSS

* Requires Rear Crankshaft Seal
 (Not Included) in addition to short block kit

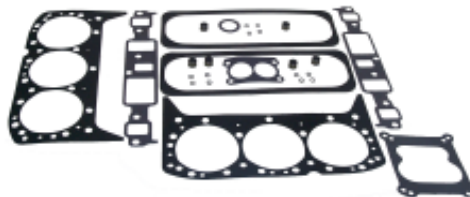

VALVE GRIND KIT 18-1275
AP# 2531^①
— CONTAINS —

Description	Sierra #	AP #
Head Gasket	18-3879	1469
2BBL Carb Mounting Gasket	18-0994	333
4BBL Carb Mounting Gasket	18-0463	2533
Intake Manifold Gasket	18-4408	1470
Valve Cover Gasket	18-0311	1471
Valve Stem Seals (6)	18-4024	2538
Valve Stem Seals (12)	18-0518	792
Distributor Mounting Gasket	18-0874	373

① Does not include oil pan gasket ② Does not include intake/exhaust manifold gaskets NSS Not Sold Separately

INTERNAL ENGINE COMPONENTS

A-PDF Split DEMO

Modular Gasket Kit Applications



MODULAR GASKET KITS

CHEVY V-6 262/4.3L — 1 Piece Rear Seal CHEVY V-6 262/4.3L GEN II — 1 Piece Rear Seal

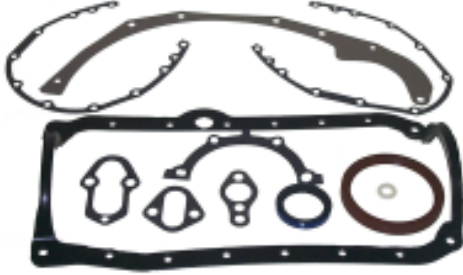

SHORT BLOCK KIT 18-1270 AP# 2566* — CONTAINS —

Description	Sierra #	AP #
Oil Pan Gasket	18-0405	—
Oil Drain Screw Gasket	18-0905	356
Forward Crankshaft Seals	18-1213	1055
Rear Crankshaft Seal	18-0519	1806
Crankshaft Seal Retainer	18-0322	1474
Water Pump Mounting Gasket	18-0891	352
Fuel Pump Plate Gasket	NSS	NSS
Fuel Pump Mounting Gasket	18-0889	348
Timing Chain Cover Gasket	18-0976	1129
Timing Chain Cover Gasket	NSS	NSS

* Requires Rear Crankshaft Seal (Not Included) in addition to short block kit

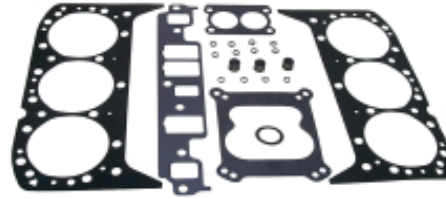

VALVE GRIND KIT 18-1278 — CONTAINS —

Description	Sierra #	AP #
Head Gasket	18-3879	1469
2BBL Carb Mounting Gasket	18-0994	333
4BBL Carb Mounting Gasket	18-0463	2533
Valve Stem Seals (6)	18-4024	2538
Valve Stem Seals (12)	18-0518	792
Distributor Mounting Gasket	18-0874	373
Intake Gasket Set	18-1238	2541
Valve Cover Gasket (2)	18-0311	1471

CHEVY V-8 305/5.0L 2 Piece Rear Seal



SHORT BLOCK KIT 18-1265 AP# 2561* — CONTAINS —

Description	Sierra #	AP #
Oil Pan Gasket	18-0153	737
Oil Drain Screw Gasket	18-0905	356
Oil Filter Gasket	18-0185	555
Forward Crankshaft Seal	18-1213	1055
Rear Crankshaft Seal	18-1211	279
Water Pump Mounting Gasket	18-0891	352
Water Pump Plate Gasket	NSS	NSS
Fuel Pump Plate Gasket	18-0876	531
Fuel Pump Mounting Gasket	18-0889	348
Timing Chain Cover Gasket	18-0976	1129
Vent Adapter Gasket	NSS	NSS

* Except Stbd Dip Stick models

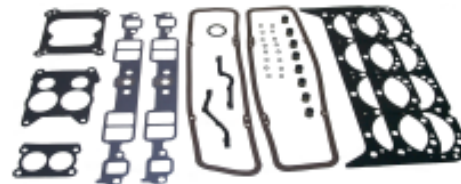

VALVE GRIND KIT 18-1266 AP# 2562② — CONTAINS —

Description	Sierra #	AP #
Head Gasket	18-3876	526
2BBL Carb Mounting Gasket	18-0994	333
4BBL Carb Mounting Gasket	18-0463	2533
4BBL Carb Mounting Gasket	18-0462	104
Intake Manifold Gasket	18-0868	527
Valve Cover Gasket (2)	18-2845	1611
Valve Stem Seals (8)	18-4024	2538
Valve Stem Seals (16)	18-0518	792
Distributor Mounting Gasket	18-0874	373

① Does not include oil pan gasket

② Does not include intake/exhaust manifold gaskets

NSS Not Sold Separately

INT. ENG.

MODULAR GASKET KITS

CHEVY V-8 305/5.0L (Right Hand Rotation) 2 Piece Rear Seal

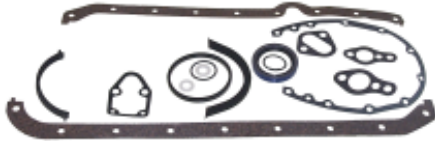

SHORT BLOCK KIT 18-1262 AP# 2558*

— CONTAINS —

Description	Sierra #	AP #
Oil Pan Gasket	18-0153	737
Oil Drain Screw Gasket	18-0905	356
Oil Filter Gasket	18-0185	555
Forward Crankshaft Seal	18-1213	1055
Rear Crankshaft Seal	18-1216	2537
Water Pump Mounting Gasket	18-0891	352
Water Pump Plate Gasket	NSS	NSS
Fuel Pump Plate Gasket	18-0876	531
Fuel Pump Mounting Gasket	18-0889	348
Timing Chain Cover Gasket	18-0976	1129
Vent Adapter Gasket	NSS	NSS

* Except Stbd Dip Stick Models

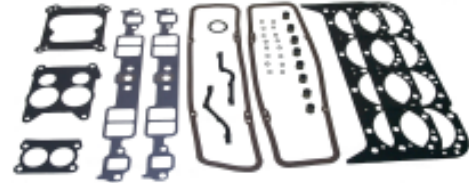

VALVE GRIND KIT 18-1266 AP# 2562®

— CONTAINS —

Description	Sierra #	AP #
Head Gasket	18-3876	526
2BBL Carb Mounting Gasket	18-0994	333
4BBL Carb Mounting Gasket	18-0463	2533
4BBL Carb Mounting Gasket	18-0462	104
Intake Manifold Gasket	18-0868	527
Valve Cover Gasket (2)	18-2845	1611
Valve Stem Seals (8)	18-4024	2538
Valve Stem Seals (16)	18-0518	792
Distributor Mounting Gasket	18-0874	373

CHEVY V-8 305/5.0L GEN II 1 Piece Rear Seal

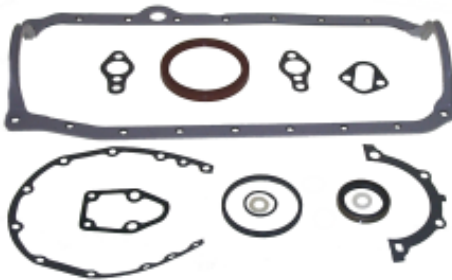

SHORT BLOCK KIT 18-1268 AP# 2564^①

— CONTAINS —

Description	Sierra #	AP #
Oil Pan Gasket	18-0905	356
Oil Filter Gasket	18-0185	555
Forward Crankshaft Seal	18-1213	1055
Rear Crankshaft Seal	18-0519	1806
Rear Main Bearing Gasket	18-0322	1474
Water Pump Mounting Gasket	18-0891	352
Water Pump Plate Gasket	NSS	NSS
Fuel Pump Plate Gasket	18-0976	1129
Fuel Pump Mounting Gasket	18-0889	348
Timing Chain Cover Gasket	18-0468	2536

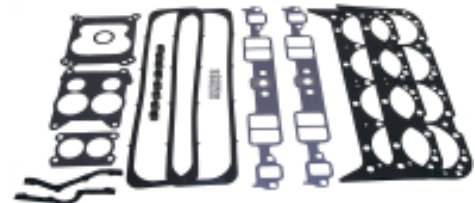

VALVE GRIND KIT 18-1267 AP# 2563^②

— CONTAINS —

Description	Sierra #	AP #
Head Gasket	18-3876	526
2BBL Carb Mounting Gasket	18-0994	333
4BBL Carb Mounting Gasket	18-0463	2533
4BBL Carb Mounting Gasket	18-0462	104
Intake Manifold Gasket Set	18-0868	527
Valve Cover Gasket (2)	18-0664	1219
Valve Stem Seals (8)	18-4024	2538
Valve Stem Seals (16)	18-0518	792
Distributor Mounting Gasket	18-0874	373

① Does not include oil pan gasket

② Does not include intake/exhaust manifold gaskets

NSS Not Sold Separately

MODULAR GASKET KITS

CHEVY V-8 305/5.0L GEN II (Right Hand Rotation) 1 Piece Rear Seal

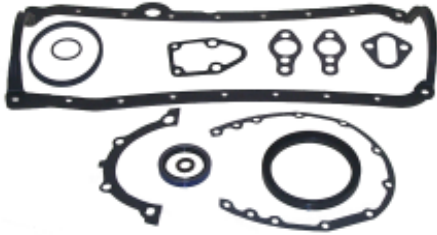

SHORT BLOCK KIT 18-1263 AP# 2559^① — CONTAINS —

Description	Sierra #	AP #
Oil Drain Screw Gasket	18-0905	356
Oil Filter Gasket	18-0185	555
Forward Crankshaft Seal	18-1213	1055
Rear Crankshaft Seal	18-1215	1761
Rear Main Bearing Gasket	18-0322	1474
Water Pump Mounting Gasket	18-0891	352
Water Pump Plate Gasket	NSS	NSS
Fuel Pump Plate Gasket	18-0876	531
Fuel Pump Mounting Gasket	18-0889	348
Timing Chain Cover Gasket	18-0468	2536

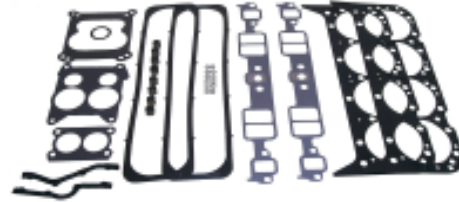

VALVE GRIND KIT 18-1267 AP# 2563^② — CONTAINS —

Description	Sierra #	AP #
Head Gasket	18-3876	526
2BBL Carb Mounting Gasket	18-0994	333
4BBL Carb Mounting Gasket	18-0463	2533
4BBL Carb Mounting Gasket	18-0462	104
Intake Manifold Gasket Set	18-0868	527
Valve Cover Gasket (2)	18-0664	1219
Valve Stem Seals (8)	18-4024	2538
Valve Stem Seals (16)	18-0518	792
Distributor Mounting Gasket	18-0874	373

CHEVY V-8 350/5.7L 2 Piece Rear Seal



SHORT BLOCK KIT 18-1265 AP# 2561* — CONTAINS —

Description	Sierra #	AP #
Oil Pan Gasket	18-0153	737
Oil Drain Screw Gasket	18-0905	356
Oil Filter Gasket	18-0185	555
Forward Crankshaft Seal	18-1213	1055
Rear Crankshaft Seal	18-1211	279
Water Pump Mounting Gasket	18-0891	352
Water Pump Plate Gasket	NSS	NSS
Fuel Pump Plate Gasket	18-0876	531
Fuel Pump Mounting Gasket	18-0889	348
Timing Chain Cover Gasket	18-0976	1129
Vent Adapter Gasket	NSS	NSS

* Except Stbd Dip Stick models

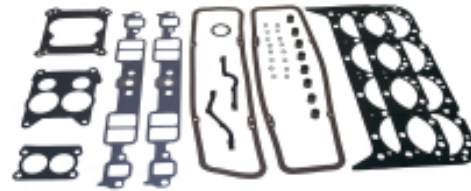

VALVE GRIND KIT 18-1266 AP# 2562^② — CONTAINS —

Description	Sierra #	AP #
Head Gasket	18-3876	526
2BBL Carb Mounting Gasket	18-0994	333
4BBL Carb Mounting Gasket	18-0463	2533
4BBL Carb Mounting Gasket	18-0462	104
Intake Manifold Gasket	18-0868	527
Valve Cover Gasket (2)	18-2845	1611
Valve Stem Seals (8)	18-4024	2538
Valve Stem Seals (16)	18-0518	792
Distributor Mounting Gasket	18-0874	373

① Does not include oil pan gasket

② Does not include intake/exhaust manifold gaskets

NSS Not Sold Separately

MODULAR GASKET KITS

CHEVY V-8 350/5.7L (Right Hand Rotation) 2 Piece Rear Seal

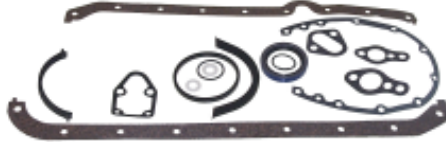

SHORT BLOCK KIT 18-1262 AP# 2558* — CONTAINS —

Description	Sierra #	AP #
Oil Pan Gasket	18-0153	737
Oil Drain Screw Gasket	18-0905	356
Oil Filter Gasket	18-0185	555
Forward Crankshaft Seal	18-1213	1055
Rear Crankshaft Seal	18-1216	2537
Water Pump Mounting Gasket	18-0891	352
Water Pump Plate Gasket	NSS	NSS
Fuel Pump Plate Gasket	18-0876	531
Fuel Pump Mounting Gasket	18-0889	348
Timing Chain Cover Gasket	18-0976	1129
Vent Adapter Gasket	NSS	NSS

* Except Stbd Dip Stick Models



VALVE GRIND KIT 18-1266 AP# 2562② — CONTAINS —

Description	Sierra #	AP #
Head Gasket	18-3876	526
2BBL Carb Mounting Gasket	18-0994	333
4BBL Carb Mounting Gasket	18-0463	2533
4BBL Carb Mounting Gasket	18-0462	104
Intake Manifold Gasket	18-0868	527
Valve Cover Gasket (2)	18-2845	1611
Valve Stem Seals (8)	18-4024	2538
Valve Stem Seals (16)	18-0518	792
Distributor Mounting Gasket	18-0874	373

CHEVY V-8 350/5.7L GEN II 1 Piece Rear Seal

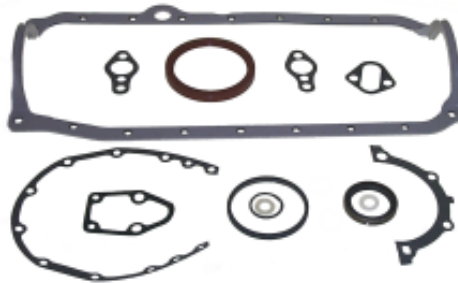

SHORT BLOCK KIT 18-1268 AP# 2564① — CONTAINS —

Description	Sierra #	AP #
Oil Pan Gasket	18-0905	356
Oil Filter Gasket	18-0185	555
Forward Crankshaft Seal	18-1213	1055
Rear Crankshaft Seal	18-0519	1806
Rear Main Bearing Gasket	18-0322	1474
Water Pump Mounting Gasket	18-0891	352
Water Pump Plate Gasket	NSS	NSS
Fuel Pump Plate Gasket	18-0976	1129
Fuel Pump Mounting Gasket	18-0889	348
Timing Chain Cover Gasket	18-0468	2536

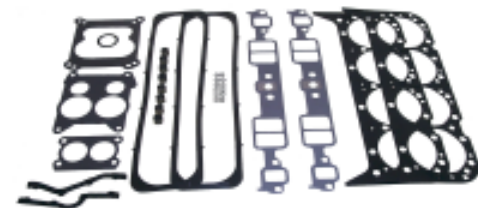

VALVE GRIND KIT 18-1267 AP# 2563② — CONTAINS —

Description	Sierra #	AP #
Head Gasket	18-3876	526
2BBL Carb Mounting Gasket	18-0994	333
4BBL Carb Mounting Gasket	18-0463	2533
4BBL Carb Mounting Gasket	18-0462	104
Intake Manifold Gasket Set	18-0868	527
Valve Cover Gasket (2)	18-0664	1219
Valve Stem Seals (8)	18-4024	2538
Valve Stem Seals (16)	18-0518	792
Distributor Mounting Gasket	18-0874	373

① Does not include oil pan gasket ② Does not include intake/exhaust manifold gaskets NSS Not Sold Separately

INTERNAL ENGINE COMPONENTS

A-PDF Split DEMO Modular Gasket Kit Applications



MODULAR GASKET KITS

CHEVY V-8 350/5.7L GEN II (Right Hand Rotation) 1 Piece Rear Seal

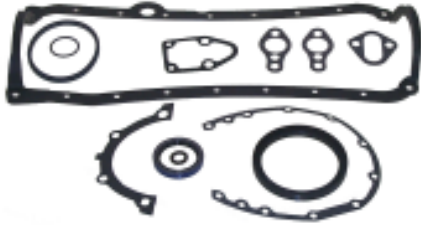

SHORT BLOCK KIT 18-1263 AP# 2559^①

— CONTAINS —

Description	Sierra #	AP #
Oil Drain Screw Gasket	18-0905	356
Oil Filter Gasket	18-0185	555
Forward Crankshaft Seal	18-1213	1055
Rear Crankshaft Seal	18-1215	1761
Rear Main Bearing Gasket	18-0322	1474
Water Pump Mounting Gasket	18-0891	352
Water Pump Plate Gasket	NSS	NSS
Fuel Pump Plate Gasket	18-0876	531
Fuel Pump Mounting Gasket	18-0889	348
Timing Chain Cover Gasket	18-0468	2536



VALVE GRIND KIT 18-1267

AP# 2563^②

— CONTAINS —

Description	Sierra #	AP #
Head Gasket	18-3876	526
2BBL Carb Mounting Gasket	18-0994	333
4BBL Carb Mounting Gasket	18-0463	2533
4BBL Carb Mounting Gasket	18-0462	104
Intake Manifold Gasket Set	18-0868	527
Valve Cover Gasket (2)	18-0664	1219
Valve Stem Seals (8)	18-4024	2538
Valve Stem Seals (16)	18-0518	792
Distributor Mounting Gasket	18-0874	373

CHEVY V-8 454/7.4L



SHORT BLOCK KIT 18-1256

AP# 2552*

— CONTAINS —

Description	Sierra #	AP #
Oil Pan Gasket	18-0348	733
Oil Drain Screw Gasket	18-0905	356
Forward Crankshaft Seal	18-1233	—
Rear Crankshaft Seal	18-0520	1074
Water Pump Mounting Gasket	18-0903	536
Fuel Pump Mounting Gasket	18-0889	348
Timing Cover Gasket	18-0980	537
* Right Hand Rotation Engines Require		
Rear Crankshaft Seal	18-1214	2495

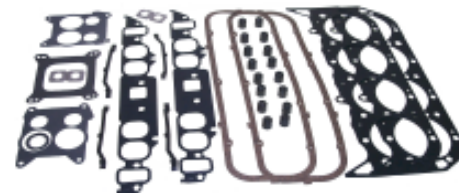

VALVE GRIND KIT 18-1257

AP# 2553^②

— CONTAINS —

Description	Sierra #	AP #
Head Gasket	18-3877	533
Carb Mounting Gasket	NSS	NSS
Carb Mounting Gasket	NSS	NSS
Carb Mounting Gasket	NSS	NSS
Intake Manifold Gasket Set	NSS	NSS
Valve Cover Gasket (2)	NSS	NSS
Valve Stem Seals (16)	NSS	NSS
Distributor Mounting Gasket	18-0874	373

① Does not include oil pan gasket ② Does not include intake/exhaust manifold gaskets NSS Not Sold Separately

INT. ENG.

MODULAR GASKET KITS

CHEVY V-8 454/7.4L w/Square Ports

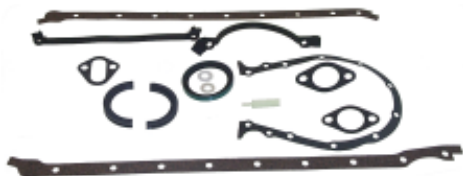

SHORT BLOCK KIT 18-1256
AP# 2552*
 — CONTAINS —

Description	Sierra #	AP #
Oil Pan Gasket	18-0348	733
Oil Drain Screw Gasket	18-0905	356
Forward Crankshaft Seal	18-1233	—
Rear Crankshaft Seal	18-0520	1074
Water Pump Mounting Gasket	18-0903	536
Fuel Pump Mounting Gasket	18-0889	348
Timing Cover Gasket	18-0980	537
* Right Hand Rotation Engines Require		
Rear Crankshaft Seal	18-1214	2495



VALVE GRIND KIT 18-1259
AP# 2555^②
 — CONTAINS —

Description	Sierra #	AP #
Head Gasket	18-3877	533
Carb Mounting Gasket	18-0467	2534
Carb Mounting Gasket	18-0463	2533
Carb Mounting Gasket	18-0462	104
Intake Manifold Gasket Set	18-1231	2526
Valve Cover Gasket (2)	18-0464	532
Valve Stem Seals (16)	18-4024	2538
Distributor Mounting Gasket	18-0874	373

CHEVY V-8 454/7.4L GEN V CHEVY V-8 454/7.4L GEN V (w/square ports)

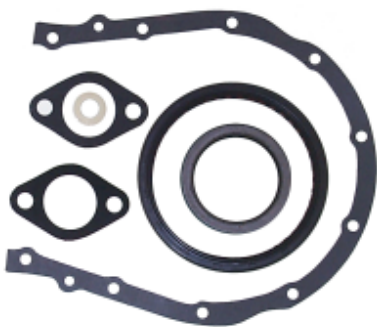

SHORT BLOCK KIT 18-1261
AP# 2557^①
 — CONTAINS —

Description	Sierra #	AP #
Oil Drain Screw Gasket	18-0905	356
Forward Crankshaft Seals	18-1233	—
Rear Crankshaft Seals	18-1234	2497
Water Pump Mounting Gasket	18-0903	536
Timing Cover Gasket	18-0468	2536



VALVE GRIND KIT 18-1258
AP# 2554^②
 — CONTAINS —

Description	Sierra #	AP #
Head Gasket	18-3887	533
Carb Mounting Gasket	18-0467	2534
Carb Mounting Gasket	18-0463	2533
Carb Mounting Gasket	18-0462	104
Intake Manifold Gasket Set	18-1231	—
Valve Stem Seals (16)	NSS	NSS
Distributor Mounting Gasket	18-0874	373

① Does not include oil pan gasket

② Does not include intake/exhaust manifold gaskets

NSS Not Sold Separately

INTERNAL ENGINE COMPONENTS

A-PDF Split DEMO
Modular Gasket Kit Applications



MODULAR GASKET KITS

CHEVY V-8 502/8.2L



SHORT BLOCK KIT 18-1255 AP# 2551 — CONTAINS —

Description	Sierra #	AP #
Oil Pan Gasket	18-0340	521
Forward Crankshaft Seals	18-1213	1055
Rear Crankshaft Seals	18-1211	279
Push Rod Cover	18-0329	1124
Water Pump Gasket	18-0327	346
Fuel Pump Mounting Gasket	18-0889	348
Timing Gear Cover Gasket	18-0887	355
Distributor Mounting Gasket	18-0874	373
*Right Hand Rotation Engines Require		
Rear Crankshaft Seal	18-1214	2495



VALVE GRIND KIT 18-1259 AP# 2555^② — CONTAINS —

Description	Sierra #	AP #
Head Gasket	18-3877	533
Carb Mounting Gasket	18-0467	2534
Carb Mounting Gasket	18-0463	2533
Carb Mounting Gasket	18-0462	104
Intake Manifold Gasket Set	18-1231	2526
Valve Cover Gasket (2)	18-0464	532
Valve Stem Seals (16)	18-4024	2538
Distributor Mounting Gasket	18-0874	373

CHEVY V-8 502/8.2L GEN V

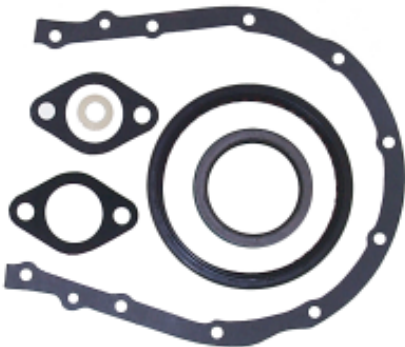

SHORT BLOCK KIT 18-1261 AP# 2557^① — CONTAINS —

Description	Sierra #	AP #
Oil Drain Screw Gasket	18-0905	356
Forward Crankshaft Seals	18-1233	—
Rear Crankshaft Seals	18-1234	2497
Water Pump Mounting Gasket	18-0903	536
Timing Cover Gasket	18-0468	2536



VALVE GRIND KIT 18-1258 AP# 2554^② — CONTAINS —

Description	Sierra #	AP #
Head Gasket	18-3887	533
Carb Mounting Gasket	18-0467	2534
Carb Mounting Gasket	18-0463	2533
Carb Mounting Gasket	18-0462	104
Intake Manifold Gasket Set	18-1231	—
Valve Stem Seals (16)	NSS	NSS
Distributor Mounting Gasket	18-0874	373

① Does not include oil pan gasket

② Does not include intake/exhaust manifold gaskets

NSS Not Sold Separately

INT. ENG.

MODULAR GASKET KITS

FORD V-8 302/5.0L 1977-93



SHORT BLOCK KIT 18-1272
AP# 2568*
 — CONTAINS —

Description	Sierra #	AP #
Oil Pan Gasket	18-0407	734
Forward Crankshaft Seal	18-1230	2546
Rear Crankshaft Seal	18-0528	2547
Water Pump Mounting Gasket	NSS	NSS
Fuel Pump Mounting Gasket	18-0889	348
Timing Chain Cover Gasket	NSS	NSS
Oil Pump Screen Gasket	NSS	NSS
* Right Hand Rotation Engines Require		
Forward Crankshaft Seal	18-1230	2546
Rear Crankshaft Seal	18-1201	2545



VALVE GRIND KIT 18-1273
AP# 2580²
 — CONTAINS —

Description	Sierra #	AP #
Head Gasket (2)	18-3883	540
4BBL Carb Mounting Gasket	18-0357	543
2BBL Carb Mounting Gasket	18-0360	544
Intake Manifold Gasket Set	18-0366	—
Valve Cover Gasket (2)	18-0352	541
Valve Stem Seals (16)	18-4023	542

FORD V-8 351/5.8L 1977-93



SHORT BLOCK KIT 18-1269
AP# 2565*
 — CONTAINS —

Description	Sierra #	AP #
Oil Pan Gasket	18-0611	1211
Forward Crankshaft Seal	18-1230	2546
Rear Crankshaft Seal	18-1223	1075
Water Pump Mounting Gasket	NSS	NSS
Fuel Pump Mounting Gasket	18-0889	348
Timing Chain Cover Gasket	NSS	NSS
Oil Pump Screen Gasket	NSS	NSS
* Right Hand Rotation Engines Require		
Forward Crankshaft Seal	18-1230	2546
Rear Crankshaft Seal	18-1201	2545



VALVE GRIND KIT 18-1273/AP# 2580²
 — CONTAINS —

Description	Sierra #	AP #
Head Gasket (2)	18-3883	540
4BBL Carb Mounting Gasket	18-0357	543
2BBL Carb Mounting Gasket	18-0360	544
Intake Manifold Gasket Set	18-0366	—
Valve Cover Gasket (2)	18-0352	541
Valve Stem Seals (16)	18-4023	542

① Does not include oil pan gasket ② Does not include intake/exhaust manifold gaskets NSS Not Sold Separately

INTERNAL ENGINE COMPONENTS

A-PDF Split DEMO Modular Gasket Kit Applications



INT. ENG.

MODULAR GASKET APPLICATION				
Engine/Model	Years	Serial No.	Sierra Short Block	Sierra Valve Grind Kit
Chevy 153-2.5L	1965-85	3377341-6229717 ^⑤ ^②	18-1271	18-1274
Chevy 153/2.5L	1986-88	6229718 & Up ^⑤ ^②	18-1271	18-1274
Chevy 181/3.0L	1973-84	3332137-6229717 ^⑤ ^② ^⑥	18-1271	18-1274
Chevy 181/3.0L	1985-96	6229718 & Later ^⑤ ^② ^⑥	18-1271	18-1274
Chevy 181/3.0Lx	1990-97	C856559 & Later ^① ^⑤ ^②	N/A	18-1274
MerCruiser 165/ 3.7L (4 Cyl.)	1987-89	6916779 & Later ^⑦ ^③	18-1276	18-1277
MerCruiser 170 (4 Cyl.)	1985-86	6916779 & Later ^③	18-1276	18-1277
MerCruiser 180/ 3.7L-Lx (4 Cyl.)	1987-89	6916779 & Later ^③	18-1276	18-1277
MerCruiser 190 (4 Cyl.)	1985-86	6916779 & Later ^③	18-1276	18-1277
MerCruiser 470	1976-82	4208730-6218036 ^③	18-1276	18-1277
MerCruiser 470	1983-84	6218037-6916778 ^③	18-1276	18-1277
MerCruiser 485	1980-82	5685394-6218036 ^③	18-1276	18-1277
MerCruiser 488	1983-84	6170297-6916778 ^③	18-1276	18-1277
Chevy 229/3.8L	1983-84	6330183-6919655 ^② ^⑤	18-1270	18-1275
Chevy L6 250/4.1L	1970-81	2770032-5813433 ^⑤	18-1255	18-1264
Chevy 262/4.3L (2Pc. Rm Seal)	1985	6919656-B455459 ^⑤	N/A	18-1275
Chevy 262/4.3L (2Pc. Rm Seal)	1986-92	A483581 ^① ^⑤	18-1270	18-1275
Chevy 262/4.3L Gen II	1992	D714370-F802999 ^① ^⑤	18-1270	18-1278
Chevy 262/4.3L Gen II	1993-96	D714370-F802999 ^① ^⑤	18-1270	18-1278
Chevy 305/5.0L	1977-85	4762210-B525981 ^③ ^⑤	18-1265	18-1266
Chevy 305/5.0L (Rev. Rota.)	1977-85	4762210-B525981 ^③ ^⑤	18-1262	18-1266
Chevy 305/5.0L (1 Pc. Rm Seal)	1986	A482027-B525981 ^① ^⑤	18-1258	18-1266
Chevy 305/5.0L (Rev. Rota.) (1 Pc. Rm Seal)	1986	A482027-B525981 ^① ^⑤	18-1263	18-1266
Chevy 305/5.0L	1987-95	B525982 & Later ^① ^⑤ ^⑧	18-1268	18-1267
Chevy 305/5.0L Inboard	1987-95	B522506 & Later ^① ^⑤ ^⑧	18-1268	18-1267
Chevy 305/5.0L (Rev.Rota) Inboard	1987-95	B522506 & Later ^① ^⑤	18-1263	18-1267
Chevy 350/5.7L	1975-86	4175500-B525982 ^③ ^⑤ ^④	18-1265	18-1266
Chevy 350/5.7 Inboard	1975-86	4498701-B522506 ^③ ^⑤	18-1265	18-1266
Chevy 350/5.7 (Rev.Rota) Inboard	1975-86	4498701-B522506 ^③ ^⑤	18-1262	18-1266
Chevy 350/5.7L (1Pc. Rm Seal)	1986	6218462-B522506 ^① ^⑤	18-1268	18-1266

① Full circle Rear Crankshaft Seal, one Piece Pan Gasket

② 3.8L models require 18-1211 Rear Crank Seal and 18-0362 Oil Pan Gasket

③ Starboard dip stick models require 18-0411 Pan Gasket

④ Four Piece Oil Pan Set

⑤ Head & valve cover gaskets included in valve grind kit

⑥ Thermostat housing, mounting & exhaust gaskets not included

⑦ Intake/Exhaust Manifold Gasket included in kit

⑧ 18-1216 Rear Main Crankshaft Seal also required

⑨ Includes Thermostat

⑩ 18-1214 Rear Main Crankshaft Seal also required

⑪ Crankshaft Seals also required

⑫ Models with cast push rod cover require 18-0328

⑬ Crankshaft Seals not included in short block kit

⑭ Use 18-4349 for serial no.6218462-B525981

⑮ For models with one piece rear main seal use 18-1206 Kit

MODULAR GASKET APPLICATION (Cont.)				
Engine/Model	Years	Serial No.	Sierra Short Block	Sierra Valve Grind Kit
Chevy 350/5.7L (1Pc. Rm Seal) Inboard	1986	A492879-B522506 ① ⑤	18-1268	18-1266
Chevy 350/5.7L (Rev.Rota) (1 Pc. Rm Seal)	1986	A492879-B522506 ① ⑤	18-1263	18-1266
Chevy 350/5.7L	1987-95	B525982 & Later ① ⑤ ⑧	18-1268	18-1267
Chevy 350/5.7L	1996-97	B525982 & Later ① ⑤ ⑧	18-1268	18-1267
Chevy 350/5.7L Inboard	1987-95	B522506 & Later ① ⑤	18-1263	18-1267
Chevy 350/5.7L Inboard	1996-97	B522506 & Later ① ⑤	18-1263	18-1267
Chevy 350/5.7L (Rev.Rota.) Inboard	1987-95	B522506 & Later ① ⑤	18-1263	18-1267
Chevy 350/5.7L (Rev. Rota.) Inboard	1996-97	B522506 & Later ① ⑤	18-1263	18-1267
Chevy 454/7.4L	1977-92	4623115-D937001⑤	18-1256	18-1257
Chevy 454/7.4L Inboard	1977-92	4623110 & Later ⑤	18-1256	18-1257
Chevy 454/7.4L (Rev.Rota.) Inboard	1977-92	4623110 & Later ⑤ ⑩	18-1256	18-1257
Chevy 454/7.4L (Sq. Ports)	1988-91	B721206-D805068 ⑤	18-1256	18-1259
Chevy 454/7.4L Gen V	1992-94	D603118 & Later ⑤	18-1261	18-1258
Chevy 454/7.4L Gen V	1995-97	D603118 & Later ⑤	18-1261	18-1258
Chevy 454/7.4L Gen V Inboard	1992-94	D715494 & Later ⑤	18-1261	18-1258
Chevy 454/7.4L Gen V Inboard	1995-97	D715494 & Later ⑤	18-1261	18-1258
Chevy 454/7.4L Gen V (Sq. Ports)	1992-94	D805069 & Later ⑤	18-1261	18-1260
Chevy 454/7.4L Gen V (Sq. Ports)	1995-97	D805069 & Later ⑤	18-1261	18-1260
Chevy 502/8.2L	1990-92	C84992-F213244 ⑤	18-1256	18-1259
Chevy 502/8.2L Inboard	1990-92	C878221-D857199 ⑤	18-1256	18-1259
Chevy 502/8.2L Gen V	1993-97	D824589 & Later ⑤	18-1261	18-1260
Chevy 502/8.2L Gen V Inboard	1993-97	D857200 & Later ⑤	18-1261	18-1260
Ford 302/5.0L	1971-77	3108723-4887829 ④ ⑤	18-1272	18-1273
Ford 351/5.8L	1975-77	4173000-4902304 ④ ⑤	18-1269	18-1273
Ford 351/5.8L (Rev. Rota.)	1975-77	4173000-4902304 ④ ⑤ ①	18-1269	18-1273

- ① Full circle Rear Crankshaft Seal, one Piece Pan Gasket
- ② 3.8L models require 18-1211 Rear Crank Seal and 18-0362 Oil Pan Gasket
- ③ Starboard dip stick models require 18-0411 Pan Gasket
- ④ Four Piece Oil Pan Set
- ⑤ Head & valve cover gaskets included in valve grind kit
- ⑥ Thermostat housing, mounting & exhaust gaskets not included

- ⑦ Intake/Exhaust Manifold Gasket included in kit
- ⑧ 18-1216 Rear Main Crankshaft Seal also required
- ⑨ Includes Thermostat
- ⑩ 18-1214 Rear Main Crankshaft Seal also required
- ① Crankshaft Seals also required
- ② Models with cast push rod cover require 18-0328
- ③ Crankshaft Seals not included in short block kit
- ④ Use 18-4349 for serial no.6218462-B525981
- ⑤ For models with one piece rear main seal use 18-1206 Kit

SEE PAGES 121-122 FOR OUR COMPLETE LINE OF GASKET SEALANT

INTERNAL ENGINE COMPONENTS

A-PDF Split DEMO
Gasket Sets



ENGINE OVERHAUL GASKET SETS

(Sets do not include Front and Rear Crankshaft Seals)

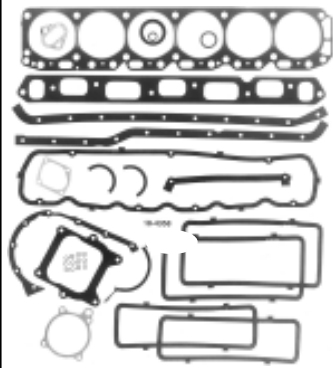

18-4358

Replaces: Mercruiser 27-801841
For: 250 CID Engines/ 160, 165 HP

— CONTAINS —			
Sierra#	AP#	Description	O.E.# Qty.
18-0175	—	O-Ring	25-26543 4
18-0860	425	O-Ring	25-62700 1
18-0864	1285	Seal	26-90925 1
18-0881	565	Exhaust Elbow Mtg Gasket	27-18272 1
18-0992	1494	Exhaust Manifold Mounting Gasket	27-68715 1
18-0994	333	Carburetor Mounting Gasket	27-70143-1 1
18-0158	334	Intake Manifold Gasket	27-70905 1
18-0111	357	Exhaust Elbow Mounting Gasket	27-89657 2
18-0160	390	Lower Exhaust to Intake Manifold Gasket	27-94136 1
18-0113	414	Exhaust Elbow Mounting Gasket	27-97542 1
18-2843	335	Thermostat Cover Gasket	27-74830 1
18-2848	359	QuadraJet Base Gasket	27-52457-2 1
18-3878	551	Head Gasket	27-13709T 1
18-7121	233	O-Ring	25-35027 1
18-0874	350	Distributor Gasket	27-34486 1
18-0185	555	Seal	27-91892 1
18-2555	341	Thermostat Gasket	27-89656-1 1
18-0889	348	Fuel Pump Mounting Gasket	27-34213 1
18-4366	1528	Oil Pan Gasket Set	27-72479A5 1
18-0387	—	Flywheel Cover Gasket	27-94976 1
18-0172	147	Oil Seal	26-97530 2

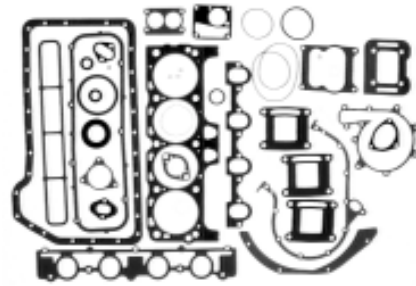

18-4381
AP# 1072

Replaces: Mercruiser 27-43186A1
For: 224 (3.7L) CID Eng; 165, 170, 180, 190 HP
S/N 6916779 & UP

— CONTAINS —			
Sierra#	AP#	Description	O.E.# Qty.
18-0864	1285	Seal	26-90925 1
18-0992	1494	Exhaust Manifold Mounting Gasket	27-68715 1
18-0158	334	Intake Manifold Gasket	27-70905 1
18-0950	386	Impeller Cover Gasket	27-88046 1
18-0954	389	Exhaust Mounting Gasket	27-92720 1
18-0113	414	Exhaust Elbow Mounting Gasket	27-97542 1
18-2832	314	Manifold End Cap Gasket	27-48043-1 2
18-2833	398	Exhaust Elbow To Manifold Gasket	27-99777-2 2
18-2843	335	Thermostat Cover Gasket	27-74830 1
18-3878	551	Head Gasket	27-13709T 1
18-0175	—	O-Ring	25-26543 4
18-0889	348	Fuel Pump Mounting Gasket	27-34213 1
18-7121	233	O-Ring	25-35029 1
18-0874	373	Distributor Gasket	27-34486-3 1
18-0928	379	Manifold End Cap Gasket	27-73814 1
18-0994	333	Carb. Mounting Gasket	27-70143-1 1
18-2555	341	Thermostat Cover Gasket	27-89656-1 1
18-4366	1528	Oil Pan Gasket Set	27-72479A5 1
18-0387	—	Flywheel Cover Gasket	27-94976 1

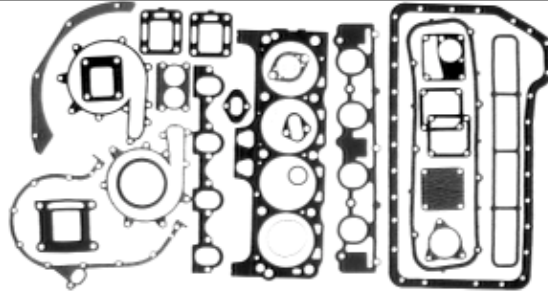

18-4382
AP# 1065

Replaces: Mercruiser 27-74830A3
For: 224 (3.7L) CID Eng; 470 S/N 4208730 & UP

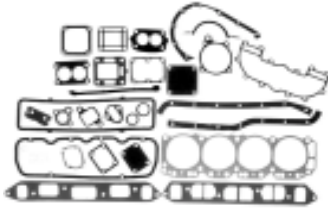

18-4383
AP# 735

For: GM 153 (2.5L) CID Eng; S/N 2324347 & UP

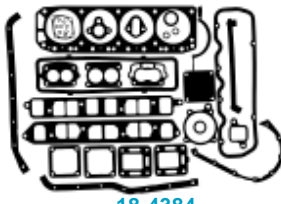

18-4384
AP# 745

For: GM 181 (3.0L) CID Eng; S/N 2508261 & UP
(Except 3.0LX)



18-4385
AP# 550

For: Ford 302 (5.0L) CID Eng; 215, 225 & 888 (188 HP)
Includes 18-3883/AP# 540 Head Gasket

— CONTAINS —			
Sierra#	AP#	Description	O.E.# Qty.
18-0976	1129	Timing Chain Cover Gasket	27-14250 1
18-0868	527	Intake Manifold Gasket	27-17145 1
18-0872	—	Exhaust Manifold Gasket	27-33395 2
18-0897	524	Exhaust Elbow Mounting Gasket	27-41813 1
18-0885	315	Exhaust Elbow Mounting Gasket	27-48042 4
18-2917	418	Lower Thermostat Housing Gasket	27-53045-1 1
18-0153	737	Port Dip Gasket	27-85817A1 1
18-2848	359	Quadrajet Base Gasket	27-58457-2 2
18-2849	385	Exhaust Elbow To Manifold Gasket	27-87105-1, 27-818832 4
18-3876	526	Head Gasket	27-75611 2
18-2551	—	Thermostat Gasket	27-90556 2
18-2554	525	Thermostat Gasket	27-41812 1
18-2832	314	Manifold End Cap Gasket	27-48043-1 4
18-2553	354	Thermostat Gasket	27-47510 1
18-2833	398	Exhaust Elbow To Manifold Gasket	27-99777-2 4
18-2844	331	Thermostat Cover Gasket	27-48818-1 1
18-0889	348	Fuel Pump Housing Gasket	27-34213 1
18-0891	352	Water Pump Mounting Gasket	27-34897 1
18-0905	356	Oil Pan Drain Plug Gasket	27-49955 1
18-0876	531	Water Pump Mounting Gsk	27-34898 1
18-0994	333	Carb. Mounting Gasket	27-70143-1 2
18-0518	792	Seal	26-34217 16
18-2845	1611	Valve Cover Gasket	121-122 2

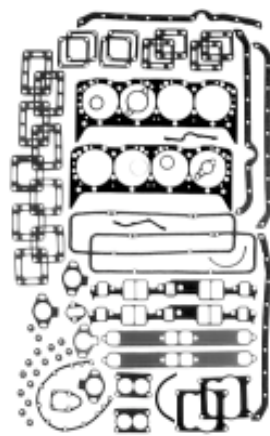

18-4386

For: GM 305 & 350 (5.0L & 5.7L) CID Eng;
With Heads (1987 & Earlier)

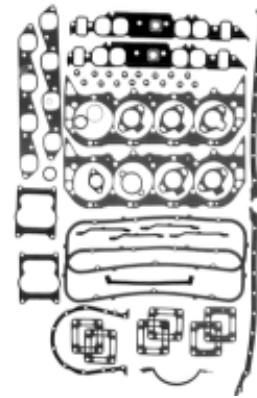

18-4387
AP# 538

Replaces: Mercruiser 27-801853
For: GM 454 (7.4L) CID Eng; Production Models
Oval Port
Includes 18-3877/AP# 533 Head Gasket

SEE PAGES 97-98 FOR OUR COMPLETE LINE OF GASKET SEALANTS

INT. ENG.

CYLINDER HEAD AND INTAKE MANIFOLD GASKET SETS



18-0465
AP# 535

Replaces: Mercruiser 27-65184
 OMC 352670, 14024393
 Crusader 31134
 For: GM 454 CID Engines, 325, 330, 340, 350 HP
 and 454 Magnums, 7.4L



18-4365

Replaces: Mercruiser 27-801855
 For: GM 454 (7.4L) CID Eng; Production Models
 Rectangular Port
Includes 18-3877/AP# 533 Head Gasket

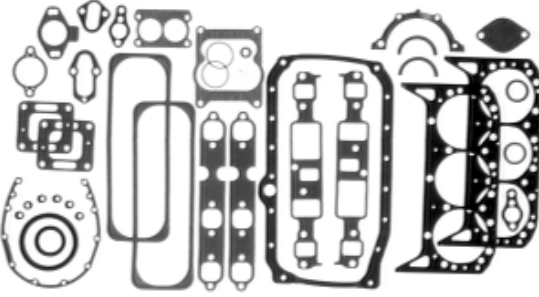

18-4388
AP# 1500

Replaces: Mercruiser 27-11977A88, A92
 For: GM 262 CID Eng; 175, 185 & 205 HP, 4.3L
Includes 18-3879 Head Gasket

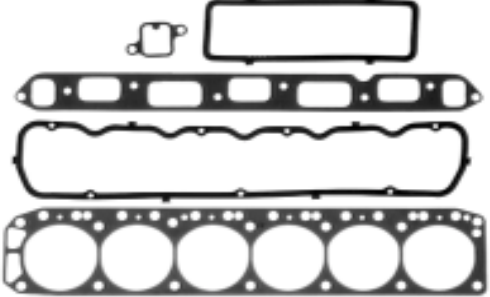

18-4389
AP# 1612

Replaces: Mercruiser 27-47453A1
 For: All GM 165 HP (S/N 270032 & UP) & Inline 6 cyl.
 250 CID



18-4390

Replaces: Mercruiser 27-56110A1
 For: Ford 302 CID Eng; 215, 225 HP, 888 (188 HP), 5.0L
 S/N 4615129 & BELOW
Includes 18-3883/AP# 540 Head Gasket

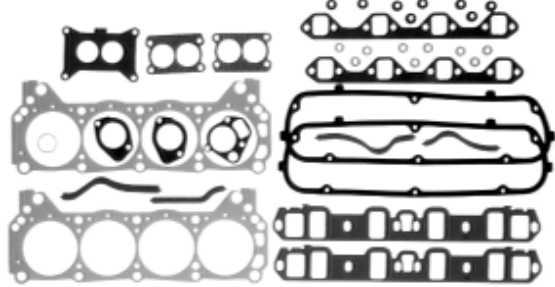

18-4391

Replaces: Mercruiser 27-64763A2
 For: Ford 351 CID Eng; 233 HP S/N 4173000-4500860, 5.8L
Includes 18-3883/AP# 540 Head Gasket

— CONTAINS —

Sierra#	AP #	Description	O.E.#	Qty.
18-0868	527	Intake Manifold Gasket	27-17145	1
18-0872	—	Exhaust Manifold Gasket	27-33395	2
18-2848	359	Quadrajel Base	27-52457-2	2
18-3876	526	Head Gasket	27-75611	2
18-2553	354	Thermostat Gasket	27-47510	1
18-2844	331	Thermostat Cover Gasket	27-48818-1	1
18-2554	636	Thermostat Gasket	27-41812	2
18-2917	418	Lower Thermostat Housing Gasket	27-53045-1	1
18-2845	1611	Valve Cover Gasket	27-11999	2
18-0518	792	Seal	26-34217	16

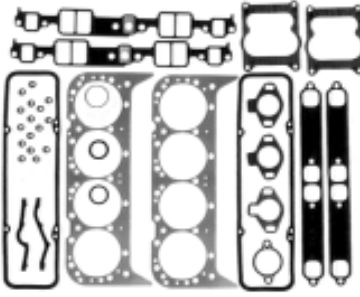

18-4392
AP# 1040

Replaces: Mercruiser 27-75611A2
 For: GM 305 & 350 CID Eng, 898 (198 HP) 200, 228,
 230/260 (Inboard) 230, 250, 255, 260, 280 & 5.7L Ski

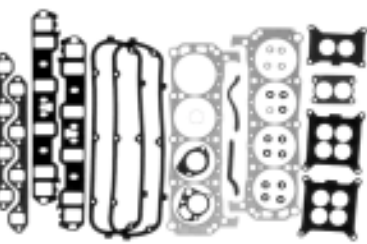

18-4393

Replaces: Mercruiser 27-75647A1
 For: Ford 302 CID Eng; 888 5.0L (188 HP)
 S/N 4615130 & UP
Includes 18-3883/AP# 540 Head Gasket, 5.0L

SEE PAGES 97-98 FOR OUR COMPLETE LINE OF GASKET SEALANTS

INT. ENG.

INTERNAL ENGINE COMPONENTS

A-PDF Split DEMO
Gasket Sets



MISCELLANEOUS GASKET SETS



18-0153
AP# 1087
PORT DIP

Replaces:
Mercruiser 27-85817A1
OMC 3931599, 458625, 357159
For: GM 350 CID (5.7L)



18-0340
AP# 521
OIL PAN GASKET SET

Replaces:
Mercruiser 27-49949
OMC 3930962, 3923440,
3929973
For: 160/165 (6 cyl.)



18-1235
AP# 13040
OIL PAN

For: Old style right hand dipstick SB Chevy



18-1239
OIL PAN

Replaces:
Mercruiser 27-810846T
Volvo 3853343
OMC 914820
For: 3.0LX (1990 & UP)

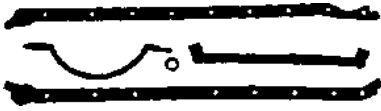

18-0348
AP# 733
OIL PAN

Replaces: Mercruiser 27-52550
OMC 3931593, 3909800, 3955115
Crusader 22048
For: GM 454/502 CID Eng; (7.4L and 8.2L)



18-1237
AP # 1626
OIL PAN

Replaces: Mercruiser 27-13865-1
Volvo 3856138
OMC 3856138
Crusader 7090380
For: Late model right hand small block Chevy



18-0466
AP# 749
OIL PAN GASKET SET

Replaces: Mercruiser 27-14901A1
OMC 3930961, 3923440, 3921473
For: GM 153/181 (2.5L & 3.0L)



18-1238
AP# 1470
INTAKE GASKET SET

Replaces: Mercruiser 27-11977
Volvo & OMC 3850374
For: 4.3L Chevrolet



PKG. OF 2

18-1231
AP# 2527
INTAKE

Replaces:
Mercruiser 27-818188-1
OMC 3854095
For: Rectangular port high performance big block Chevy

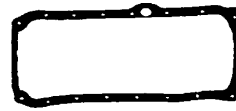

18-0405
AP# 1627
OIL PAN

Replaces:
Mercruiser 27-14247-1
Volvo 3852655
OMC 912955, 3852655
Crusader 7090190
For: GM 262 CID Eng. (4.3L)



18-0407
AP# 734
OIL PAN

Replaces: Mercruiser 27-64798
OMC C9JE-6722-A
D30E-6722-AA
C20E-6710-B, C20E-6711-B
For: Ford 302 CID Models
Mercruiser: 215, 225, 888



18-0410
INTAKE MANIFOLD SET

Replaces: Mercruiser 27-75648
Volvo 3853912, 3853913
OMC 988162/3854406
For: Ford 351 CID Eng; (233 HP)
S/N 4500861 & UP, 5.0L/302



18-0411
AP# 738
OIL PAN

Replaces:
Mercruiser 27-90458A1
OMC 14079398, 458625
357159
For: GM 350 CID (5.7L) Starboard Dipstick



18-0611
AP# 1121
OIL PAN

Replaces: Mercruiser 27-75483
For: Ford 351 CID Eng., (5.8L)



18-1232
OIL PAN

Replaces:
Mercruiser 27-811566
OMC 3853510
Crusader 7090000
For: 454 & 502 CID Eng.



18-0868
AP# 527
INTAKE MANIFOLD SET

Replaces: Mercruiser
27-17145
Volvo 3854269
OMC 985630
Crusader 21005, 7151000
For: 305, 350

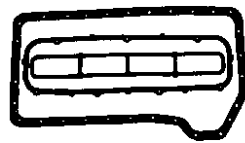

18-4366
AP# 1528
OIL PAN GASKET SET

Replaces: Mercruiser
27-72479A5
For: 224 CID (3.7L)

18-4375
AP# 747
Replaces: Mercruiser
27-34213A2
For: GM 153 & 181 CID Eng; 110, 120,
130, 140, 150, 160 & 165 HP; 2.5L & 3.0L



— CONTAINS —

Sierra#	AP#	Description	O.E.#	Qty.
18-0869	348	Fuel Pump Mounting Gasket	27-34213	1
18-0887	355	Timing Cover Gasket	27-49953	1
18-0948	748	Distributor Gasket	27-87707	1
18-0327	346	Water Pump Gasket	27-33956	1

SEE PAGES 97-98 FOR OUR COMPLETE LINE OF GASKET SEALANTS

INT. ENG.

MISCELLANEOUS GASKET SETS (Cont.)

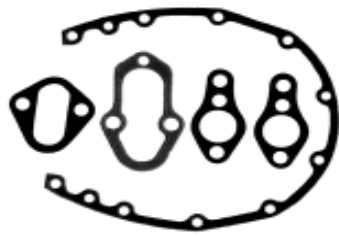

18-4377
ap# 1037
 Replaces: Mercruiser 27-42457A1
 For: GM 262 CID Eng; 175, 185 & 205 HP

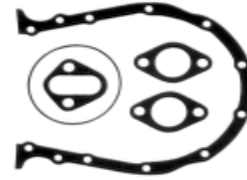

18-4378
ap# 1071
 Replaces: Mercruiser 27-54529A1
 For: GM 454 CID Eng. 325, 330, 340 & 350 Inboards & 300TRS
 — CONTAINS —

Sierra#	AP#	Description	O.E.#	Qty.
18-0889	348	Fuel Pump Mounting Gasket	27-34213	1
18-0903	536	Water Pump Gasket	27-49110	2
18-0980	537	Timing Chain Gasket	27-54529	1



18-4379
ap# 1070
 Replaces: Mercruiser 27-56108A1
 For: Ford 302 & 351 CID Engs. 215 (Inboard), 233 & 255 HP, 888 (188 HP)
 — CONTAINS —

Sierra#	AP#	Description	O.E.#	Qty.
18-0898	—	Oil Pump Mtg. Gasket	27-56859	1
18-0889	348	Fuel Pump Mounting Gasket	27-34213	1
18-0147	—	Water Pump Gasket	27-56880	1
18-0125	—	Timing Chain Gasket	27-56108	1

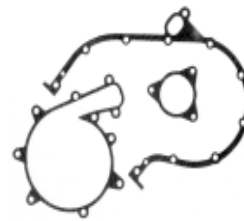

18-4380
AP# 1450
 Replaces: Mercruiser 27-68714A6
 For: Mercruiser 224 CID Eng.
 165, 170, 180, 190, 470, 485 & 488 HP

PKG. OF 2



18-0876
AP# 531
FUEL PUMP MOUNTING
 For GM 4.3L, 5.0L & 5.7L
 Replaces: Mercruiser 27-34898
 Volvo & OMC 3852113

PKG. OF 2



18-0889
AP# 348
FUEL PUMP MOUNTING
 For GM 4.3L, 5.0L & 5.7L
 Replaces: Mercruiser 27-34213
 Volvo 3852095-3

PKG. OF 2



18-0874
AP# 350
DISTRIBUTOR MOUNTING
 For GM V6 & V8
 Replaces: Mercruiser 27-34486-3
 Volvo & OMC 3852109



18-0158
AP# 334
INTAKE MANIFOLD
 Replaces: Mercruiser 27-70905
 For: 3.7L

PKG. OF 2



18-0160
AP# 390
LOWER EXHAUST TO INTAKE MANIFOLD
 Replaces: Mercruiser 27-94136



18-0183
AP# 329
EXHAUST MANIFOLD MOUNTING
 Replaces:
 Mercruiser 27-73866
 Volvo 3853742, 3852455
 OMC 908717

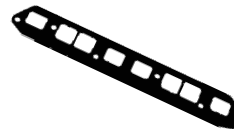

18-0680
AP# 2389
EXHAUST MANIFOLD MOUNTING
 Replaces:
 Mercruiser 27-815528
 Volvo 3853256-0
 OMC 385-3256

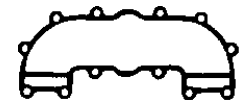

18-0332
INTAKE MANIFOLD
 Replaces:
 Mercruiser 27-35898T
 110HP (S/N 1537370-2044033)
 120HP (S/N 1666601-6229717)











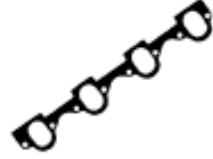

SEE PAGES 97-98 FOR OUR COMPLETE LINE OF GASKET SEALANTS

INTERNAL ENGINE COMPONENTS



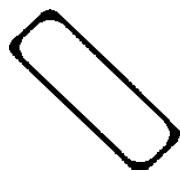





A-PDF Split DEMO
Gaskets

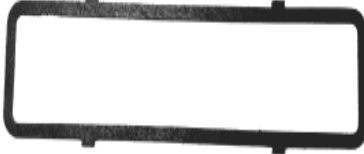

INT. ENG.

<p>PKG OF 2</p>  <p>18-0418 AP# 740 MANIFOLD TO CYLINDER HEAD Replaces: Mercruiser 27-46820 OMC 909613 GM 3852472, Barr CHVA-47-0000</p>	<p>PKG OF 2</p>  <p>18-0872 EXHAUST MANIFOLD Replaces: Mercruiser 27-33395 GM 5.0L & 5.7L</p>	 <p>18-0992 AP# 1494 EXHAUST MANIFOLD MOUNTING Replaces: Mercruiser 27-68715 OMC 912405</p>	 <p>18-1203 AP# 325 MANIFOLD TO CYLINDER HEAD Replaces: Mercruiser 27-53354 OMC 908079</p>																											
 <p>18-1204 AP# 413 MANIFOLD TO CYLINDER HEAD Replaces: Mercruiser 27-96429 OMC 912164</p>	 <p>18-2830 AP# 332 EXHAUST MANIFOLD TO CYLINDER HEAD 6 in line Replaces: Mercruiser 27-46401 OMC 907932</p>	 <p>18-2896 AP# 324 EXHAUST MANIFOLD MOUNTING Replaces: Mercruiser 27-52546 OMC 311068</p>	<p>PKG OF 2</p>  <p>18-2909 AP# 417 EXHAUST MANIFOLD TO CYLINDER HEAD GM V-6 Replaces: Mercruiser 27-99757 Volvo 856116-9 OMC 915025</p>																											
 <p>18-0468 AP# 2536 TIMING COVER GM 4.3L, 5.0L & 5.7L Replaces: Mercruiser 27-811572 Volvo 3852654, 38535-12-6 Crusader 7130240 OMC 3853512</p>	 <p>18-0311 AP# 1471 262 CID VALVE COVER Replaces: Mercruiser 27-11988 Volvo & OMC 3854942 For: 4.3 Litre</p>	 <p>18-0346 AP# 1125 VALVE COVER Replaces: Mercruiser 27-49936 OMC 3930912 For: GM250 CID (4.1L), 160/165/200(6cyl.)</p>	 <p>18-0347 AP# 357 VALVE COVER Replaces: Mercruiser 27-52145 Volvo & OMC 3852693 For: GM 153 & 181 CID (2.5L & 3.0L)</p>																											
<p>PKG OF 2</p>  <p>18-0464 AP# 532 VALVE COVER Replaces: Mercruiser 27-49121 OMC 912768 For: GM 454/502 CID (7.4L & 8.2L)</p> <table border="1"> <thead> <tr> <th>Model</th> <th>Year</th> <th>S/N</th> </tr> </thead> <tbody> <tr> <td>330</td> <td>1977-81</td> <td>4623115-6083144</td> </tr> <tr> <td>7.4 Bravo</td> <td>1988-91</td> <td>B771113-D603117</td> </tr> <tr> <td>454 Mag</td> <td>1986-92</td> <td>A631894-D805068</td> </tr> <tr> <td>370 TRS</td> <td>1978-87</td> <td>4179554-B714586</td> </tr> <tr> <td>400 TRS</td> <td>1980-86</td> <td>4179554-B457644</td> </tr> <tr> <td>400 TRS</td> <td>1983-86</td> <td>4179554-B485220</td> </tr> <tr> <td>460 TRS</td> <td>1983-86</td> <td>4179554-6181046</td> </tr> <tr> <td>502 Mag Bravo</td> <td>1990-92</td> <td>C878221-D824588</td> </tr> </tbody> </table>		Model	Year	S/N	330	1977-81	4623115-6083144	7.4 Bravo	1988-91	B771113-D603117	454 Mag	1986-92	A631894-D805068	370 TRS	1978-87	4179554-B714586	400 TRS	1980-86	4179554-B457644	400 TRS	1983-86	4179554-B485220	460 TRS	1983-86	4179554-6181046	502 Mag Bravo	1990-92	C878221-D824588	 <p>18-0352 AP# 541 VALVE COVER Replaces: Mercruiser 27-56173 Volvo 3852818 OMC 913758 For: Ford 302/351 CID (5.0L & 5.8L)</p>	
Model	Year	S/N																												
330	1977-81	4623115-6083144																												
7.4 Bravo	1988-91	B771113-D603117																												
454 Mag	1986-92	A631894-D805068																												
370 TRS	1978-87	4179554-B714586																												
400 TRS	1980-86	4179554-B457644																												
400 TRS	1983-86	4179554-B485220																												
460 TRS	1983-86	4179554-6181046																												
502 Mag Bravo	1990-92	C878221-D824588																												

SEE PAGES 97-98 FOR OUR COMPLETE LINE OF GASKET SEALANT











 <p>18-0664 AP# 1219 VALVE COVER Replaces: Mercruiser 27-17467 OMC 913270 OMC & Volvo 3852687 Crusader 7231330 For: GM305/350, 5.0 & 5.7L</p>	 <p>18-2845 AP# 1611 VALVE COVER V-8 GM 305/350 CID, 5.0 & 5.7L Replaces: Mercruiser 27-11999 OMC 912965</p>	<p>PKG. OF 2</p>  <p>18-0328 AP# 347 PUSH ROD COVER 153 & 181 CID, 120/140 (4 cyl.) with Cast Lifter Cover Replaces: Mercruiser 27-34208</p>
 <p>18-0329 AP# 1124 PUSH ROD COVER Replaces: Mercruiser 27-34209 For: 140/150/160/165 (6 cyl.)</p>	 <p>18-2815 AP# 2390 PUSH ROD COVER Replaces: Mercruiser 27-814703 Volvo & OMC 3852692 OMC 913276 For: 3.0L</p>	 <p>18-0147 WATER PUMP For Ford V-8 Replaces: Mercruiser 27-56880 Volvo & OMC 3852824</p>
 <p>18-0327 AP# 346 4 & 6 CYL. WATER PUMP Replaces: Mercruiser 27-33956 Volvo & OMC 3853342</p>	<p>PKG. OF 2</p>  <p>18-0891 AP# 352 WATER PUMP MOUNTING For GM 4.3L, 5.0L & 5.8L Replaces: Mercruiser 27-34897 Volvo & OMC 3852477</p>	<p>PKG. OF 2</p>  <p>18-0893 WATER PUMP GM 4.3L, 5.0L & 5.7L Replaces: Mercruiser 27-35380 Volvo & OMC 3850595</p>

INT. ENG.

INTERNAL ENGINE COMPONENTS

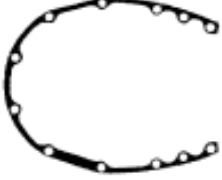
A-PDF Split DEMO
Gaskets



<p>PKG. OF 2</p>  <p>18-0891 AP# 352 WATER PUMP MOUNTING For GM 4.3L, 5.0L & 5.8L Replaces: Mercruiser 27-34897 Volvo & OMC 3852477</p>	<p>PKG. OF 2</p>  <p>18-0893 WATER PUMP GM 4.3L, 5.0L & 5.7L Replaces: Mercruiser 27-35380 Volvo & OMC 3850595</p>	 <p>18-0903 AP# 536 WATER PUMP 454 CID Replaces: Mercruiser 27-49110 OMC 3853361</p>
 <p>18-0950 AP# 386 IMPELLER COVER 224 CID Replaces: Mercruiser 27-88046</p>	<p>PKG. OF 2</p>  <p>18-0125 TIMING CHAIN For Ford V-8 Replaces: Mercruiser 27-56108 Volvo & OMC 3852767</p>	<p>PKG. OF 2</p>  <p>18-0887 AP# 355 TIMING COVER 4 & 6 CYL. Replaces: Mercruiser 27-49953 OMC & Volvo 3852691</p>
 <p>18-0976 AP# 1129 TIMING CHAIN COVER Replaces: Mercruiser 27-14250</p>	<p>PKG. OF 2</p>  <p>18-0980 AP# 537 TIMING COVER GM 7.4L Replaces: Mercruiser 27-54529 OMC 3935449 Crusader 30240</p>	 <p>18-0864 AP# 1285 REAR CRANKSHAFT SEAL 3.7L Replaces: Mercruiser 26-90925</p>
<p>PKG. OF 2</p>  <p>18-0322 AP# 1474 OIL PAN GM 5.0L & 5.7L Replaces: Mercruiser 27-14247 Volvo & OMC 3852656</p>	 <p>18-0898 OIL PUMP MOUNTING Replaces: Mercruiser 27-56859 OMC C20Z-6659-C For: Ford Engines</p>	

SEE PAGES 97-98 FOR OUR COMPLETE LINE OF GASKET SEALANT